

COESIA GROUP IN THE WORLD



**TWIN TRACK PALLET SYSTEM FOR SMART PRODUCTION**



Coesia is a group of innovation-based industrial and packaging solutions companies operating globally, headquartered in Bologna Italy, owned by Isabella Seràgnoli.

- Coesia companies are leaders in the sectors of:
- Advanced automated machinery and packaging materials
  - Industrial process solutions
  - Precision gears

Coesia customers are leading players in a broad range of industries, including Aerospace, Consumer Goods, Electronics, Healthcare, Luxury Goods, Pharmaceutical, Racing & Automotive and Tobacco.

coesia.com



info@flexlink.com  
flexlink.com

©FlexLink 5907EN 2018-02

TECHNICAL OVERVIEW

**SALES@FLEX-LINEAUTOMATION.COM**



## FOR ASSEMBLY, MACHINING AND TESTING

Functions such as transfers, locating stations and stops are all electrical.

- IIoT - ready
- Pneumatic stops optional

Pallet route, traceability tools, easy data acquisition and visualization of OEE data.

This new system increases available production time thanks to reduced pallet exchange time in the dual conveyor speed sections. The system is designed for single digit Mean Time To Repair (MTTR) and low friction accumulation that reduces wear, downtime and TCO.

The new twin track conveyor for heavy loads is fully digitalized and prepared for IIoT and traceability requirements. The system is delivered in standardized modules with pre-defined control logics shortening design and installation time which reduces time to market.

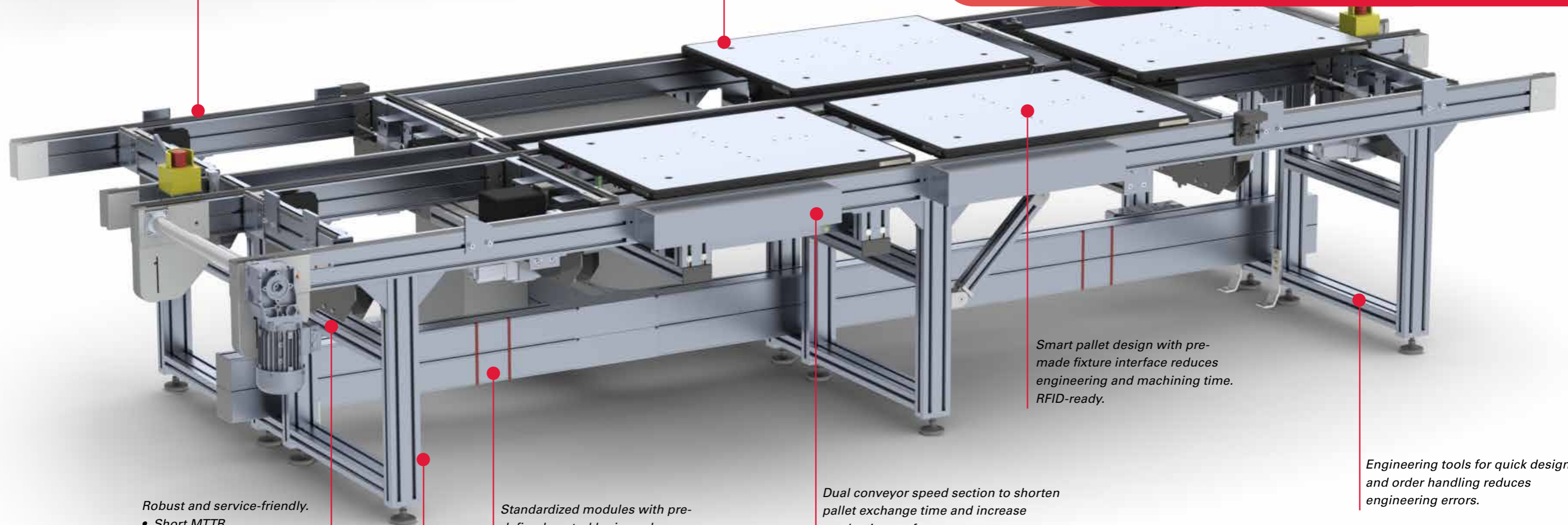

Robust and service-friendly.

- Short MTTR
- Predictive maintenance with digital chain slack detection

Standardized modules with pre-defined control logics reduce programming, and enable true plug-and-play and easy integration.

Aluminium beam with steel roller chain, steel slide rail on top and plastic on return. The return chain runs inside the beam.

Dual conveyor speed section to shorten pallet exchange time and increase production performance.

Smart pallet design with pre-made fixture interface reduces engineering and machining time. RFID-ready.

Engineering tools for quick design and order handling reduces engineering errors.

### KEY TECHNICAL DATA

- Speed: 15 m/min
- Pallet sizes: up to 1040x1040 mm
- Max. pallet load: 200 kg
- Max. accumulating load: 1000 kg
- Max. conveyor length: 10 m



**ROBUST AND SERVICE FRIENDLY**

The new conveyor has a Mean Time Between Failures (MTBF) of 12.000h (2 years with 3 shifts) where all functions are plug-and-play and mounted in fixed positions, allowing a single digit MTTR. The smart motors permit predictive maintenance. Wear is also considerably reduced thanks to the low friction steel roller chain, smart motors and dual conveyor speed zone.

**ROBUST BEAM AND CHAIN**

The HU beam is designed for rigidity, smooth running and low noise. The T-slots ensure easy but firm attachment of accessories. The upper slide rail is made of stainless steel, whereas the lower of plastic. The return chain runs within the beam.

Choose between three types of chain:

- Steel roller chain
- Steel off-set roller top chain
- Steel roller chain - lubrication free

**VERSATILE PALLETS**

The aluminum pallets come with an electrically conductive frame and are RFID-ready. The pallet is designed with an accurate fixture interface and tooled in relation to the locating holes. The system offers various pallet sizes.

**Standard pallet sizes:**

		Pallet length				
		PW, PL	480	640	800	1040
Pallet width	480		◦	◦	◦	
	640			◦	◦	◦
	800				◦	◦
	1040					◦

## TWIN TRACK CONVEYOR SYSTEM FOR SMART PRODUCTION



### TRANSFER UNIT

The totally electrical transfer is designed in two sections to facilitate installation and maintenance: lift and drive section. The module includes pre-defined control logics for quick and easy set-up.



### LOCATING UNIT

The locating unit stops the pallet and locates it with a repeatability of +/-0,1 mm. The locating pins are situated on one side but machined in the same piece to achieve perfect accuracy. The module is electrical and includes pre-defined control logics.



### DRIVES AND SMART MOTORS

The smart asynchronous motors only run when needed and thanks to the low friction conveyor design you can configure longer conveyors per drive. This reduces torque by 50 %. Motor control can be integrated or separate. A chain tensioner with a proximity switch for alarming is optional.



### STANDARDIZED LINE CONTROL

The conveyor modules include FlexLink standard controls logic. The line controller manages routing and track-and-trace while the FlexLink Device Controllers manage sensors, functions and smart motors. The benefits are reduced PLC programming needed and fast reconfiguration of a system.



### STOPS AND DAMPERS

The system offers a wide range of stops and dampers. The stops can be either electrical or pneumatic. FlexLink also offers a unique, patent pending gravity damper that gently slows down the pallet.



### SPEED BOOSTER

The speed booster section doubles the speed when needed and reduces the pallet exchange time by up to 50% (6s at 5m/min). The section reduces both stress on worn parts as well as noise level.



### SOFTWARE APPLICATIONS

FlexLink offers a range of software applications for designing smart production flows. The material flow and process traceability is easily configured in the routing and track-and-trace applications. Included in the suite is also Production Monitoring for OEE improvements and predictive maintenance.



### DESIGN AND SIMULATION TOOL

Experience the pallet system in virtual reality. The FlexLink Design Tool permits quick design and line simulation, helping you to identify bottlenecks and verify new line configurations and OEE. The tool reduces engineering errors, saves time and allows quick and trouble-free order handling.