

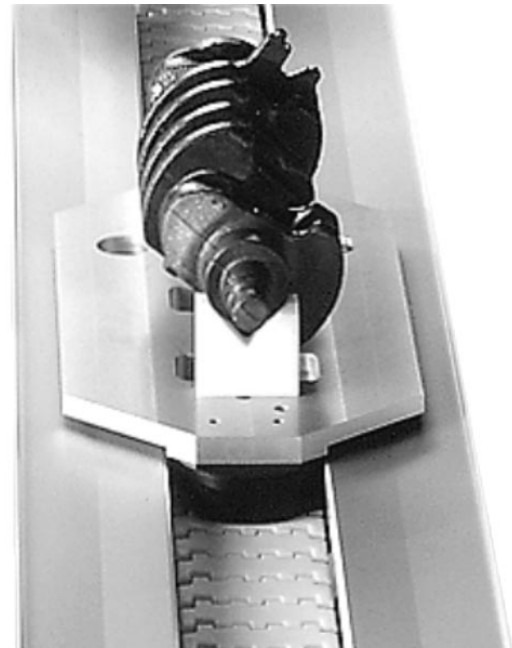

Customized pallets Conveyor system XK

Certain XK pallet applications may require pallets of non-standard size, due to the size and shape of the products conveyed.

This bulletin will give some guidelines that need to be followed when constructing, assembling and installing an XK conveyor system with customized pallets using the XK pallet guide discs.



Pallet assembly

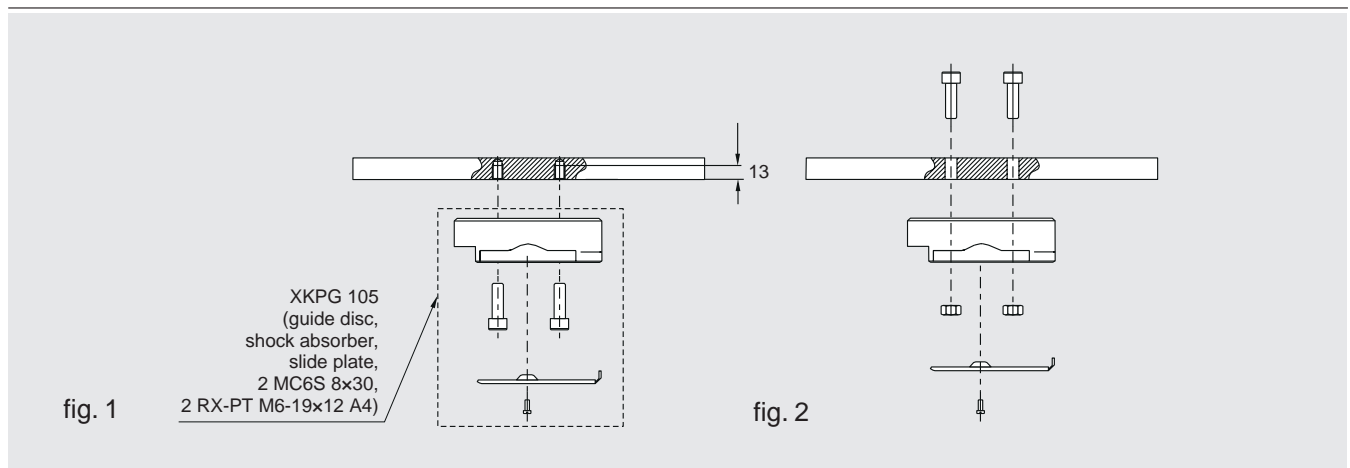

The guide disc can be mounted on to the pallet base in two ways.

Fig. 1 shows normal attachment of the pallet base from the bottom of the pallet.

The guide disc is prepared for M8 nuts and can be mounted as shown in fig. 2. (Screws and nuts for this are not included.)

Pallet dimensions

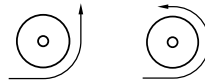
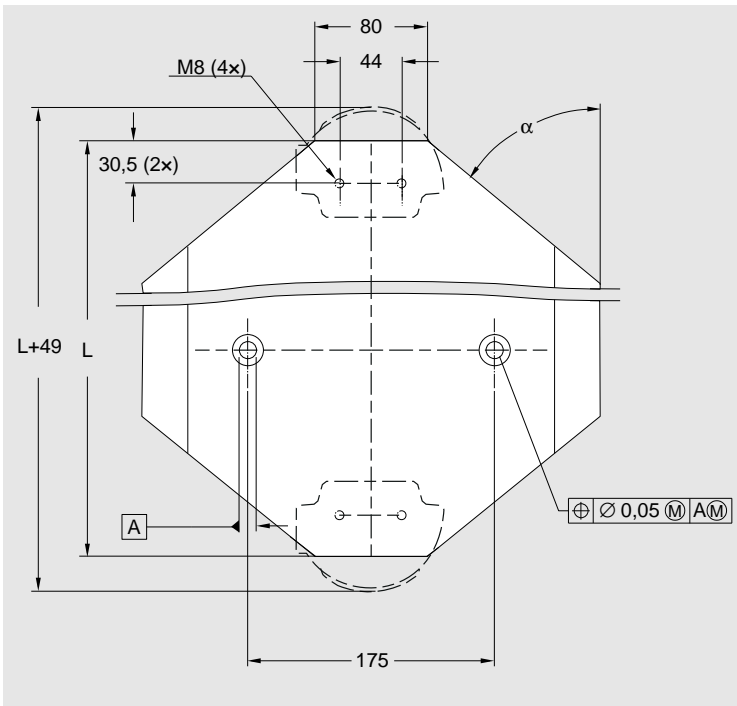

L	90° bend α	180° bend α
110	50°	68°
150	50°	60°
200	50°	52°
250	50°	45°
300*	50°	–
350	50°	–
400	50°	–
450	50°	–
500	50°	–
550	50°	–
600	50°	–

Minimum angle (α)
(Applies only if accumulation in bends exists.)

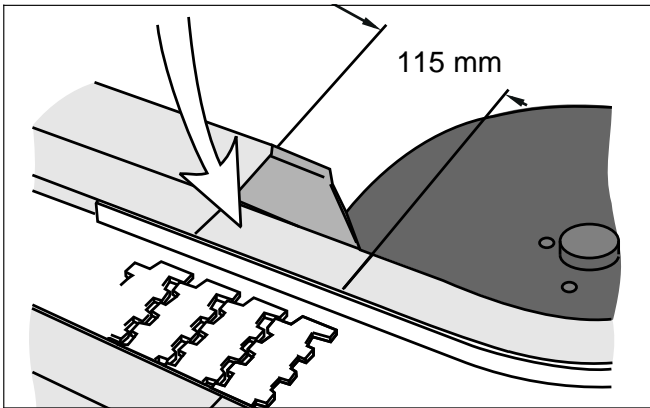

If the length of the pallet exceeds 300 mm, a 115 mm piece of XKRS guide rail has to be inserted before and after each wheel bend. This is to prevent the pallet from getting caught by the guide rail in the bend.

Pallets longer than 600 mm may not function well with the drip catcher system. If pallets longer than 600 mm are needed, contact FlexLink Systems for assistance.

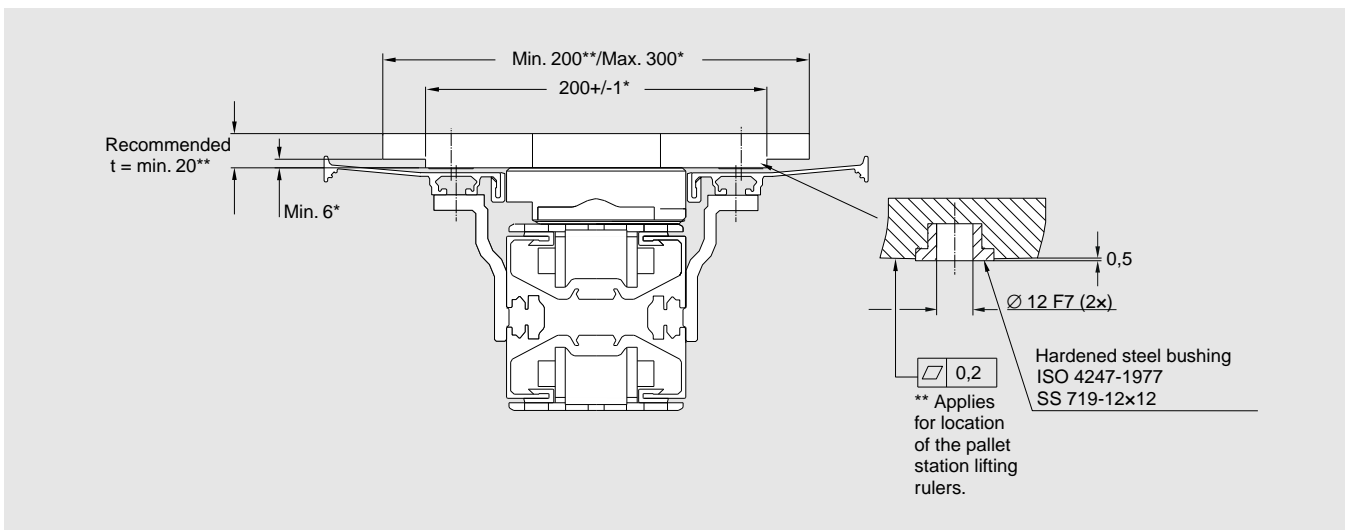

* Applies if using drip catcher system
** Applies if using pallet locating stations