



Safety cover for bend drive unit XSEW-XHEW

Safety device

All horizontal bend drive units are now delivered with a cover designed to act as a personnel safety device.

The safety cover can also be ordered separately to be mounted on to older drive units. The cover is then delivered in one standard size, but since the distance between the conveyor beams differ between XS, XL, XM and XH drive units, the cover will need to be cut at both ends to fit properly.

When mounting the cover on to older drive units, two attachment holes (M5) need to be drilled in the drive unit bracket.

Ordering information

Two MC6S 5x12 screws are required for attachment of the safety cover.



Safety cover

3905943

Safety cover

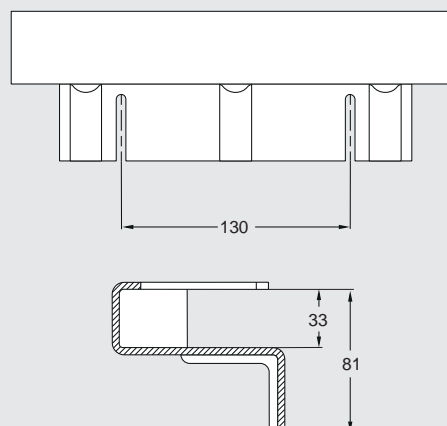

The specifications, constructional data and illustrations contained in this bulletin are not binding. We reserve the right to make alterations without prior notification.

FlexLink Systems, SE-415 50 GÖTEBORG, Sweden. Tel +46-31-337 31 00. Telefax +46-31-337 22 33.