

# Technical Bulletin



Information from FlexLink

[www.flexlink.com](http://www.flexlink.com)

No. 01-12-20

## XB 295 – for wide and bulky products

The XB product range now includes a conveyor that is 300 mm wide. It is designed to transport bulky or soft, pliable, ready-packed products which call for the stable support of a wide chain. The low profile beam supports the entire chain width, thereby permitting the transported goods to be off-center.



### New components

The XB 295 range includes the following new products:

- chain
- conveyor beam
- end drive units, with or without slip clutch
- idler unit
- horizontal plain bends, 700 and 1000 mm radius

### New designations

The following components fit both XB conveyor widths and have got new order designations:

| Component                           | Old designation | New designation |
|-------------------------------------|-----------------|-----------------|
| Beam section for chain installation | XBCC 300A175    | XBCC 300A       |
| 5° vertical bend                    | XBBV 5A175R7    | XBBV 5AR750     |
| 15° vertical bend                   | XBBV 15A175R7   | XBBV 15AR750    |

# Conveyor chain

## Introduction

The conveyor chain consists of plastic links joined together by means of plastic pivots and stainless steel pins.

The System XB chain base is similar to the XS–XK chain bases. The 295 mm wide top part, however, is much wider than the base, for efficient handling of wide products such as cardboard boxes etc., for example in the packaging and food industries.

## Plain chain XB

The XB chain is designed for gentle handling of bulky or soft ready-packed products requiring stable support on a wide chain.

The 295 mm wide chain features overlapping links that stay closed even in the tight radius bend. This minimizes the risk of jamming or tearing goods.

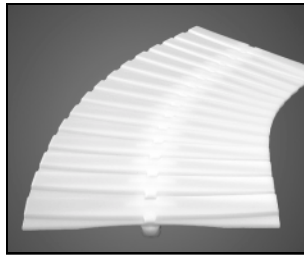

### Safety

Tight chain design minimizes the risk of fingers getting pinched in the chain.

## Chain XB

**Plain chain, 295 mm** **XB**

*New!*

Plain chain  
Length 3 m  
Including extra plastic  
pivot and steel pin      **XBTP 3A295**

Plain link      **XBTL 295**

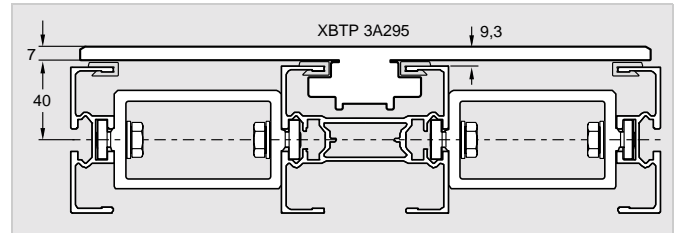

Height of chain above beam

## Ordering information

The chain comes in 3 m lengths. Separate links can also be ordered. Plastic pivots and steel pins are included with chain deliveries, so they need only be ordered with separate links or for replacement purposes.

- 1 Calculate the required length of chain. For effective track lengths of bends, drive units etc., refer to the tables "Effective track lengths" in *Conveyor engineering guidelines* in the main catalogue. Be sure to use the value for a two-way chain if the chain returns on the bottom of the beam. The chain must be ordered in 3 m sections.

## Tools and accessories for chains

### Plastic pivot and steel pin

The chain links are connected by means of plastic pivots and steel pins. Pivots and pins are included with chain deliveries, so they need only be ordered with separate links or for replacement purposes.

#### Plastic pivot

**XB**



Plastic pivot XB

**XBTT 13×16**

*Note. Must be ordered in multiples of 25*

#### Steel pin

**XB**



Steel pin XB

**XMTD 6×50**

*Note. Must be ordered in multiples of 25*

### Chain assembly tool

A special pin insertion tool is available for use when assembling and dismantling the chain. The tool helps when inserting and removing the stainless steel pin joining two chain links together.

#### Pin insertion tool for chain

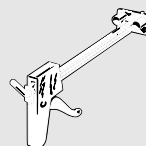

Pin insertion tool XB

**XMMJ 6**

### Chain lubrication

The chain is lubrication-free. A new chain running on new slide rails, however, will need a few hours of running-in before it runs perfectly smoothly. For applications where absolutely smooth running is essential from the start, a silicone-based lubricant (LDSS 450) is available.

#### Lubricant for chain



Silicone-based lubricant

**LDSS 450**

# Conveyor beam

## Conveyor beam XB

The chain track for straight conveyor sections consists of a middle section similar in size to the XM beam, with separate half-section beams attached on the sides to obtain the desired width (300 mm).

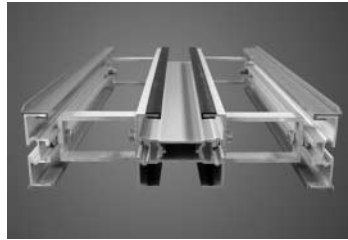

The beam sections are delivered unassembled in lengths up to 3 m. Slide rail must be ordered separately.

## Technical specifications

### Beam deflection under load

Point load  $F$  + beam weight + weight of two-way chain for 4 mm deflection (see illustration):

$$F = 1200 \text{ N}$$

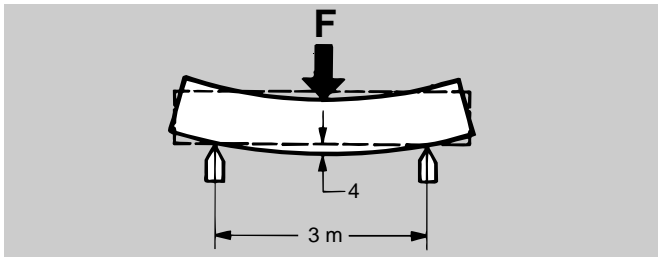

Beam deflection from straight line

## Ordering information

- 1 Determine the number of beam sections required. The beam is delivered in unassembled sections in lengths up to 3 m, or as unassembled parts.
- 2 Determine the length of slide rail required. If XBCR 25 is used, six lengths of slide rail are normally required for each length of track – four on the top side and two

on the bottom side (middle section). If XBCR 25 is used in combination with XBCR \_ UA, four lengths of regular slide rail and two lengths of slide rail for the upper outer beam sections are normally required. Do not forget bends, drive units etc. The effective track length of each such component is specified in the table "Effective track lengths" in "Conveyor engineering guidelines". Note that an extra length of slide rail is used in bends. See page 9.

- 3 Estimate the required number of plastic screws for the slide rail. Two screws are required for each separate piece of slide rail. The screws must be ordered separately. The ordered quantity must be a multiple of 50.

Determine the number of connecting strips required. Four connecting strips must be ordered separately for each joint between straight beam sections. (Bends, drive units, etc. are delivered with the necessary connecting strips.)

## Tools and accessories

The beam sections are joined together to the desired length by means of four connecting strips at each joint. For easy assembly, the two middle strips should extend 10 mm further out from the beam than the outer strips. Only the outer strips need to be secured at both ends.

The outer beam half-sections are attached to the middle section using aluminium spacers.

A special tool for the installation of slide rail (XBMR 170) is available. A snap-fit plastic or aluminium cover strip is available to cover the T-slots in the beam.

Plastic screws or aluminium rivets are used to fix the slide rail to the beam. See "Anchoring the slide rail" in Appendix A in the main catalogue.

Beam section XBCC 300A can be used to simplify chain installation. This 300 mm beam section can be opened on one side, so that the chain can be installed. After installation of the chain, the removable chain guides are returned and secured by means of screws (see Appendix C in the main catalogue).

## Beam components

### Beam section



**XB**

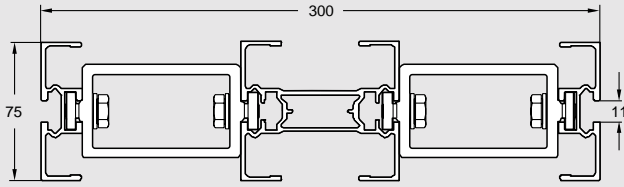

Beam section  
Length 3 m  
Length to order (0,5–3 m)

**XBCB 3A295**  
**XBCB LA295**

*The beam section is delivered unassembled.  
Slide rail: see page 4*

### Beam (outer section)

**XB**

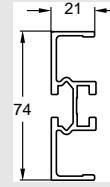

Beam (outer section)  
Length 3 m  
Length to order

**XBCB 3A H**  
**XBCB LA H**

### Beam (mid-section)

**XB**

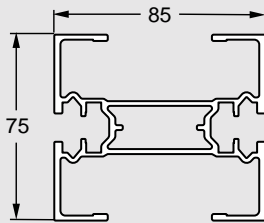

Beam (mid-section)  
Length 3 m  
Length to order

**XBCB 3A85**  
**XBCB LA85**

### Spacer



**XB**

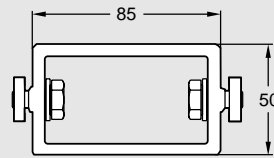

Spacer, aluminium  
Including screws and nuts

**XBCE 85**

### Beam section for chain installation

**XB**

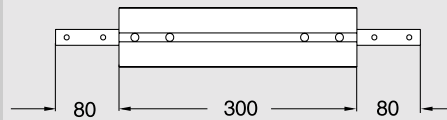

Beam section for chain installation  
Including connecting strips and screws

**XBCC 300A**

## Slide rails

### Plastic slide rail for XB beam

**XB**



Slide rail  
Length 25 m  
Polyethylene

**XBCR 25**

### Plastic slide rail, outer

**XB**

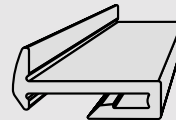

Slide rail, outer  
UHMW-PE  
Length 3 m  
Length 6 m

**XBCR 3 UA**  
**XBCR 6 UA**

## Slide rail tools and accessories

### Mounting tool for slide rail, XB

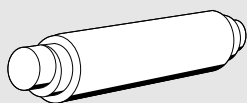

Mounting tool for slide rail

**XBMR 170**

### Drill fixture for slide rail

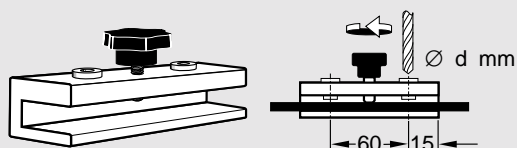

Drill fixture for XB slide rail  
d=4,2 mm

**3920500**

### Aluminium rivets

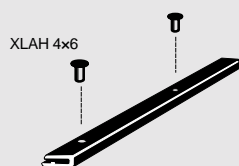

Aluminium rivets 4 mm for  
XB conveyors, brown

**XLAH 4x7**

*Note. Must be ordered in multiples of 250*

### Rivet crimping pliers



Rivet crimping pliers for XB  
For 4 mm rivets

**5051395**

### Rivet crimping clamp

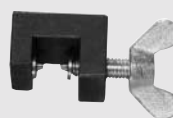

Rivet crimping clamp for XB  
For 4 mm rivets

**3923005**

### Plastic screws for slide rail

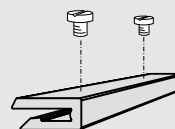

Plastic screws 5 mm for XB beams **XLAG 5**

*Note. Must be ordered in multiples of 50*

## Beam accessories

### Connecting strip with set screws

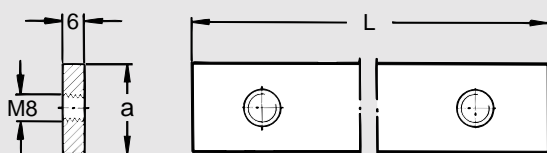

Connecting strip for XB  
a=20 mm, L=160 mm

**XSCJ 6x160**

*Note. Must be ordered in multiples of 10*

### Cover strip for T-slot, PVC

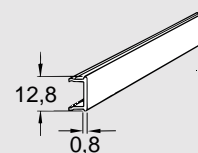

Cover strip for T-slot, PVC  
Length 3 m

**XCAC 3 P**

### Cover strip for T-slot, aluminium

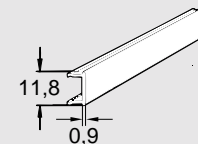

Aluminium, anodized  
Length 2 m

**XCAC 2**

# End drive units

## Direct drive

The end drive unit is available in two versions, with or without slip-clutch. These drive units are available in both left-hand and right-hand versions.

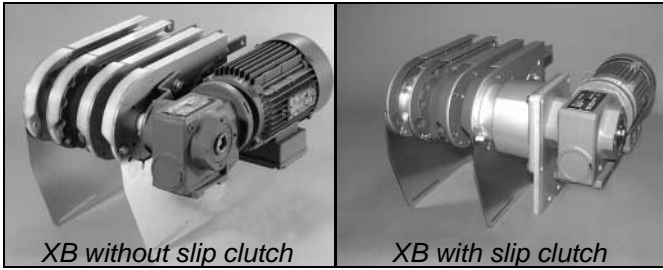

## Technical specifications

Number of teeth on drive wheel: 12  
 Chain pitch: 33,5 mm  
 Pitch diameter: 129,5 mm  
 Max. traction force: 1250 N

## Speeds

The following standard speeds are available (50 Hz):  
 5, 10, 15, 20, 25, 30, 40, 50, 60 m/min.

## Motor specifications

- Standard motor 3-phase, 400 V, 50 Hz.
- The motors can be ordered for 440–460 V, 60 Hz (not recommended for XB 60 m/min version).
- Other motor alternatives are available.

## Ordering information

- 1 Calculate the actual load and compare with the capacity of the drive unit.
- 2 The chain speed is denoted by the digit (for example 5) in the designation code. Other chain speeds are available on request.

Connecting strips are included.

## End drive units XB, without slip clutch

**End drive unit LP** *New!* **XB**

Drive unit  
 Direct drive  
 Motor on left-hand side **XBEB 5A295 LP**

*Effective track length: 0,80 m*

**End drive unit RP** *New!* **XB**

Drive unit  
 Direct drive  
 Motor on right-hand side **XBEB 5A295 RP**

*Effective track length: 0,80 m*

# End drive units XB, with slip clutch

## End drive unit LPB



**XB**

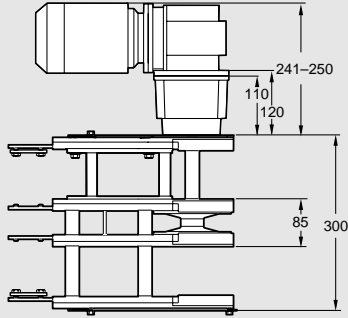
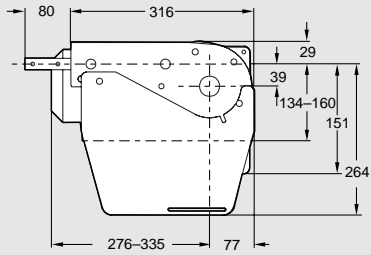

Drive unit  
 Direct drive  
 Motor on left-hand side **XBEB 5A295 LPB**  
 Effective track length: 0,80 m

## End drive unit RPB



**XB**

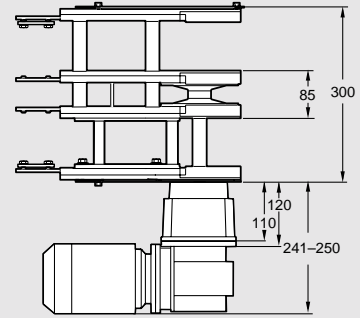
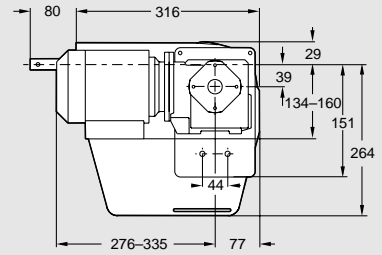

Drive unit  
 Direct drive  
 Motor on right-hand side **XBEB 5A295 RPB**  
 Effective track length: 0,80 m

# Idler unit

## Idler unit

A 180° idler end unit is available. An idler unit contains a free wheel which incorporates ball bearings. The purpose of the idler unit is to change the direction of the chain with a minimum amount of friction.

In an idler unit the chain is guided by flanges to prevent it from disengaging underneath.

## Ordering information

Connecting strips are included.

## Idler unit XB

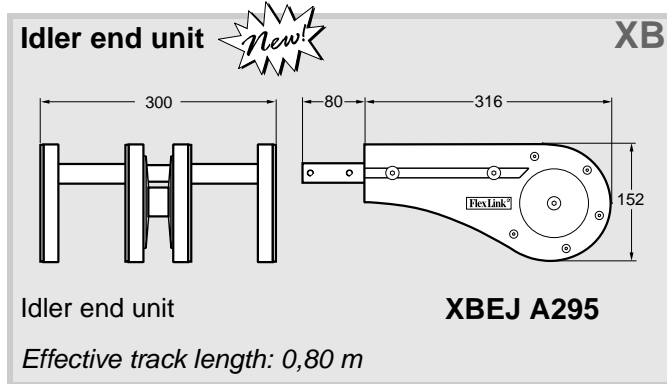

# Horizontal plain bends

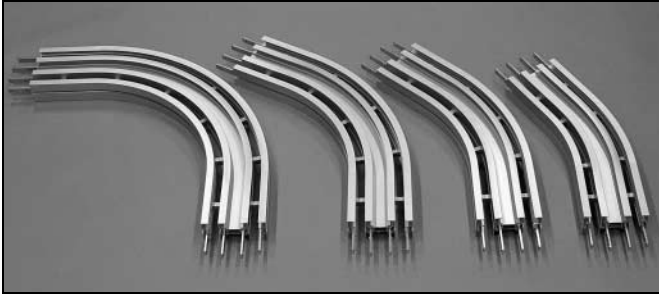

## Introduction

Horizontal plain bends are used to provide a horizontal change of direction of the conveyor. A bend consists of a middle section with separate half-section beams attached on the sides to obtain the desired width (300 mm). The outer half-beams are attached by means of spacers.

Horizontal plain bends have 200 mm straight sections at each end. The straight sections can be cut down by the user to minimum 80 mm if required.

## Extra slide rail in bends

Plain bends increase the tension in the chain and cause higher stress on the slide rail. For this purpose, a special beam profile is used in the bends, with provisions for an

extra slide rail inside the beam structure. See figure. The slide rail mounting tool has one end adapted for installation of this slide rail. Note that this slide rail must be anchored using plastic screws.

To ensure a reliable conveyor design with plain bends, always consult your FlexLink representative for technical data and design assistance.

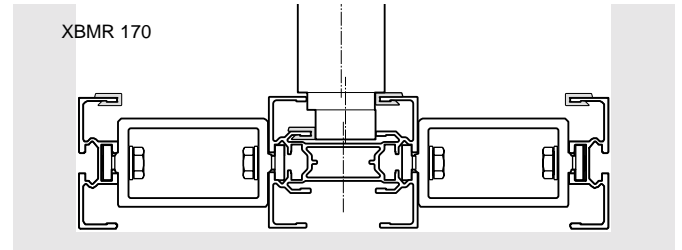

## Ordering information

- The bends are delivered in assembled sections.
- Connecting strips are included.

## Technical specifications

The standard range of plain bends has a manufacturing tolerance of  $\pm 2\%$  in radius and  $\pm 2^\circ$  in angle.

## Horizontal plain bends XB

**Horizontal plain bend, 30°** **XB**

To be released during Q2 2002

Horizontal plain bend, 30°  
 R=700 mm  
 R=1000 mm

**XBBP 30A295R7**  
**XBBP 30A295R10**

*Effective track lengths:*  
 R700: 0,80 m 1-way (1,55 m 2-way)  
 R1000: 0,95 m 1-way (1,85 m 2-way)

**Horizontal plain bend, 45°** **XB**

To be released during Q2 2002

Horizontal plain bend, 45°  
 R=700 mm  
 R=1000 mm

**XBBP 45A295R7**  
**XBBP 45A295R10**

*Effective track lengths:*  
 R700: 0,95 m 1-way (1,90 m 2-way)  
 R1000: 1,20 m 1-way (2,40 m 2-way)

### Horizontal plain bend, 60°

To be released during Q2 2002

**XB**

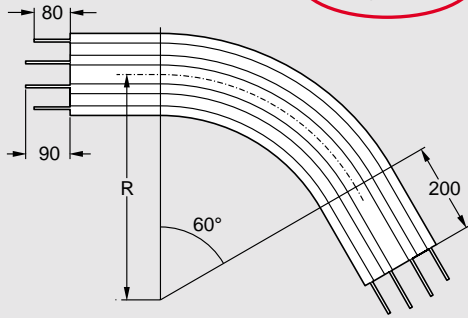

### Horizontal plain bend, 60°

R=700 mm  
R=1000 mm

**XBBP 60A295R7**  
**XBBP 60A295R10**

### Effective track lengths:

R700: 1,15 m 1-way (2,30 m 2-way)  
R1000: 1,45 m 1-way (2,90 m 2-way)

### Horizontal plain bend, 90°

To be released during Q2 2002

**XB**

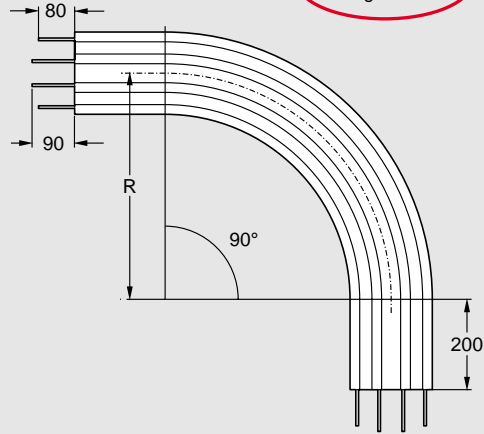

### Horizontal plain bend, 90°

R=700 mm  
R=1000 mm

**XBBP 90A295R7**  
**XBBP 90A295R10**

### Effective track lengths:

R700: 1,50 m 1-way (3,00 m 2-way)  
R1000: 2,00 m 1-way (3,95 m 2-way)

# Vertical bends

## Vertical bends

XB vertical bends are available for 5° and 15° change of direction. They consist of four separate outer section beam pieces. The conveyor bend is created by using the outer section beam pieces to connect two straight conveyor sections. The bend pieces need not be interconnected.

## Ordering information

- Connecting strips are included.
- Each bend is delivered unassembled. It consists of four outer section beam pieces.

## Vertical bends XB

**Vertical bend, 5°** **XB**

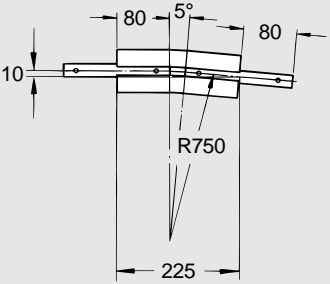

Vertical bend, 5° **XBBV 5AR750**  
Effective track length: 0,25 m 1-way (0,50 m 2-way)

**Vertical bend, 15°** **XB**

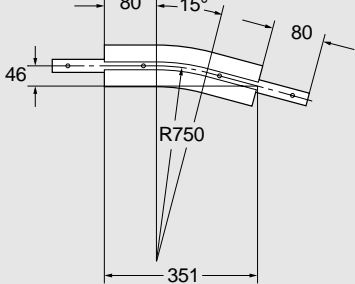

Vertical bend, 15° **XBBV 15AR750**  
Effective track length: 0,40 m 1-way (0,75 m 2-way)

## Installation of slide rail XBCR \_ UA – plain bends (XB)

Outer section:

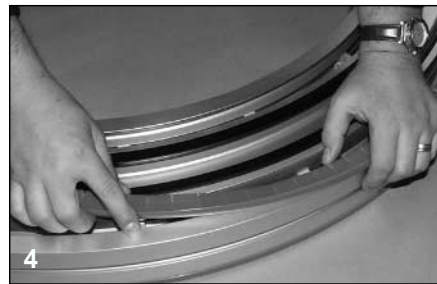
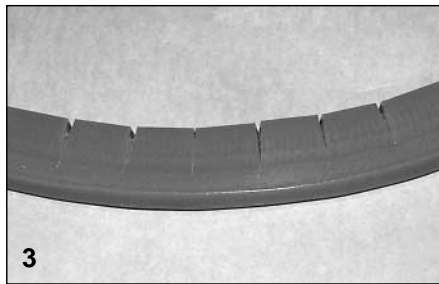
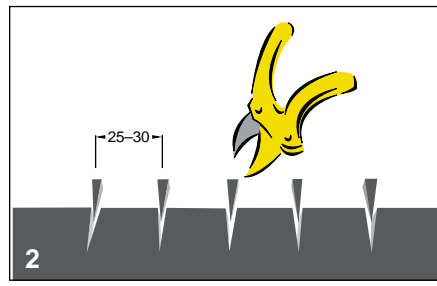
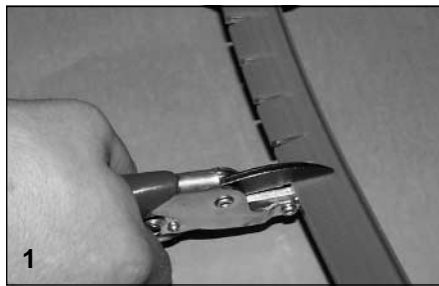

Inner section:

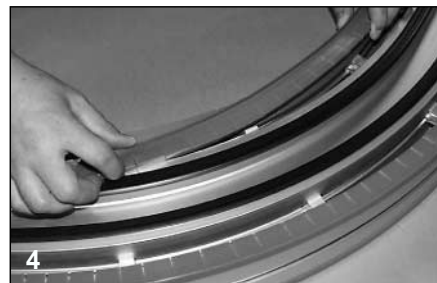
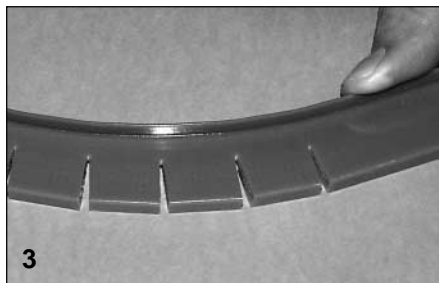
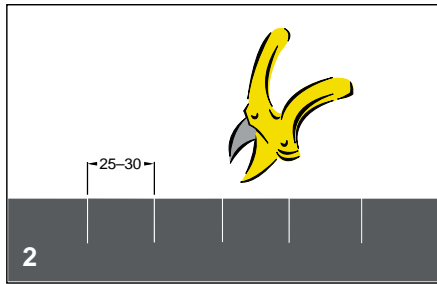
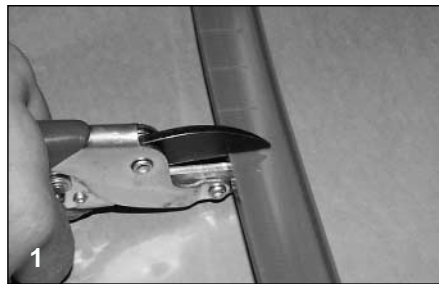

## Installation of slide rail XBCR \_ UA – drive and idler units (XB)

