

Applications



Application Bulletin from FlexLink Systems

No. 3918692-4

FlexLink Washing Unit for chain sizes XS and XL .

Problem

Keeping the FlexLink conveyor chain clean.

Dirt in the air, oil spill from the goods or machining fluid can in some industrial environments get the FlexLink chains dirty. Dirt that can have a negative effect on the environment, conveying ability of the FlexLink chain, lifetime of the chain and in the quality of the transported products.

Solution

FlexLink modular Washing Unit.

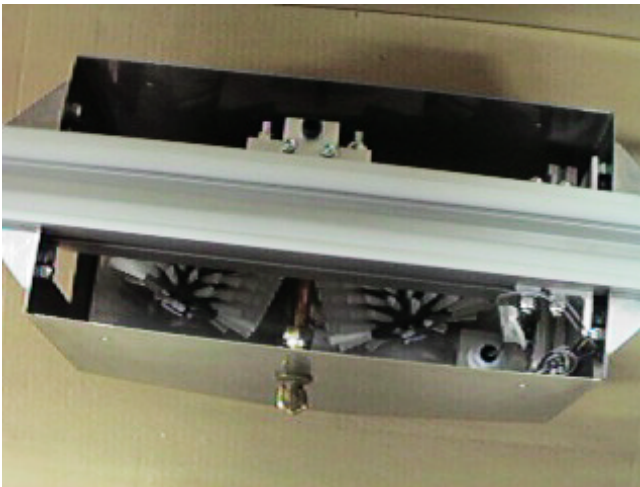

The modular Washing Unit removes chips, dirt, dust and grease from the FlexLink chain. This spray and brush washing system should, for best results, be used from the implementation of the FlexLink system and at all times when the conveyor is in operation.

The Washing Unit is easily attached to any horizontal part of FlexLink conveyor system XS and XL. The system is to be used with drip trays attached underneath the conveyor.

The major benefits of the Washing Unit are higher quality of the transported products, a longer lifetime of the chain and a cleaner appearance. As the technology advances to create better products you can add auxiliary units to help you improve your quality and environment.

Description

In many applications it is desired to provide continuous cleaning of the FlexLink chain. The Washing Unit cleans the surface of the chain and prevents the build-up of dirt, dust and abrasive particles on the chain links.

The Washing Unit is basically two oblique brushes suspended under the conveyor beam, cleaning the chain on the return path.

The brushes are driven through inclined contact with the chain. Cleaning fluid is sprayed on the brushes and a oil-resistant rubber wiper wipes the chain continuously. Excess and used fluid is collected in the surrounding tank and it is drained from the bottom by means of a return drain pipe.

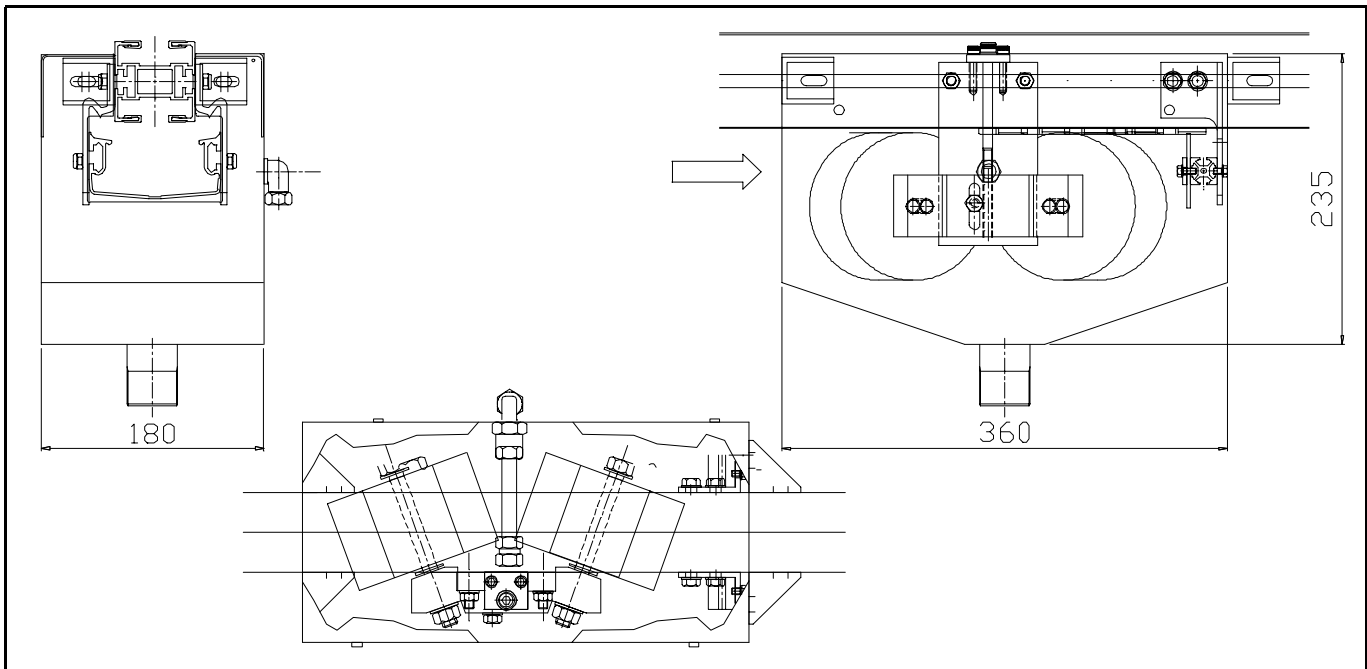

Cleaning liquid

The cleaning liquid is supplied by means of a hose or a tube connected to the copper coupling on the side of the tank. The choice of cleaning liquid is flexible with the application. It is possible to use coolant oil as a cleaning liquid and include the Washing Unit in the closed cleaning liquid system. For example if the conveyor is connected with a grinding machine, the grinding coolant can be suitable as the cleaning liquid as well.

The cleaning liquid supply could preferably be controlled with a solenoid valve connected to the on-off control of the conveyor, so that the spray function only is in use when the chain is in operation.

The Washing unit can also be equipped with overflow sensor to prevent spillage on the floor.

Technical specifications

Both washing units have standard dimensions. The complete washing unit contains a tank including lids, brush unit and wiper together with suitable fasteners for the conveyor beam.

Request for quote

You request the *Washing Units* from your local FlexLink Systems office.

Depending on the size of the conveyor there are two types of washing units. It is important that the size is mentioned in your request. Supply and drain hoses/tubes/valves are not included.

The units are delivered ready for attachment to the FlexLink conveyor beam.

Please refer to the number of the unit together with your technical specification in your request for quote.

Unit number:

Washing unit XS & XL: 39186924

Solenoid valve: 281-A-13-B-MS 24V

Overflow sensor: 35-888-52

Spareparts

Brush unit with fasteners: 3934620

Brush Ø120 mm: 3939925

Brush Ø150 mm: 3939926

(Note! One Washing unit contains two brushes).

Overflow sensor must be used in combination with solenoid valve. The solenoid valve can be used separate.

We will return a quote together with a drawing and mounting dimensions for your technical specifications.