

T wedge elevator



A FlexLink standard solution

5065-1

High capacity elevation of rolls and packs



The T wedge conveyor was designed to solve reorientation and elevation change problems. This unique solution has the ability to safely elevate products to a different level and discharge them upended in a direction 90 degrees left or right of the in-feed. Reliable operation has been proven at speeds up to 60 m/min.

The T wedge operates continuously and never requires the product to be stopped or timed. It pulls a gap between products by speeding up the product flow, to ensure product separation and enable smooth travel through the bends. Furthermore, the wedge conveyor can be used reverse as a "lowerator".

Standard features

- High capacity in-line elevation and decline
- Provides a smooth way to elevate products above head to free valuable floor space
- Provides controlled in-line reorientation of products
- Short ramp-up time due to full functioning plug&play module
- Proven robust function and high efficiency
- Space efficient
- Width adjustment system with hand wheel for speedy changeovers
- Ready for CE incorporation

T wedge conveyor

Technical specifications

Speed.....	max. 60 m/min.
Infeed height (Hi).....	300–1500 mm
Discharge height (Hd).....	1400–7000 mm
Min. height change (ΔH).....	1100 mm
Product length.....	100–600 mm
Product width.....	100–300 mm
Product height.....	100–300 mm
Max. product weight.....	5 kg

Included in delivery

Standard:

- Conveyor: FlexLink XM system with "C" type gripper chain
- Support framing: FlexLink modular system XC
- Drive units: SEW Eurodrive gear motors

Optional:

- Full enclosure: FlexLink XC system
- Movimot inverter to control motor speed, smooth starts and stops
- Motor driven linear actuators for software controlled width adjustment

Other motor types, chain cleat types, product dimensions etc. are available on request.

Installation requirements

- Power supply: 3-phase 380/460 VAC, 50/60 Hz
- Control signal (if inverter is used)
 - Potential free contacts, digital IO's
 - Profibus/Devicenet/Interbus
 - ASi

Dimensions

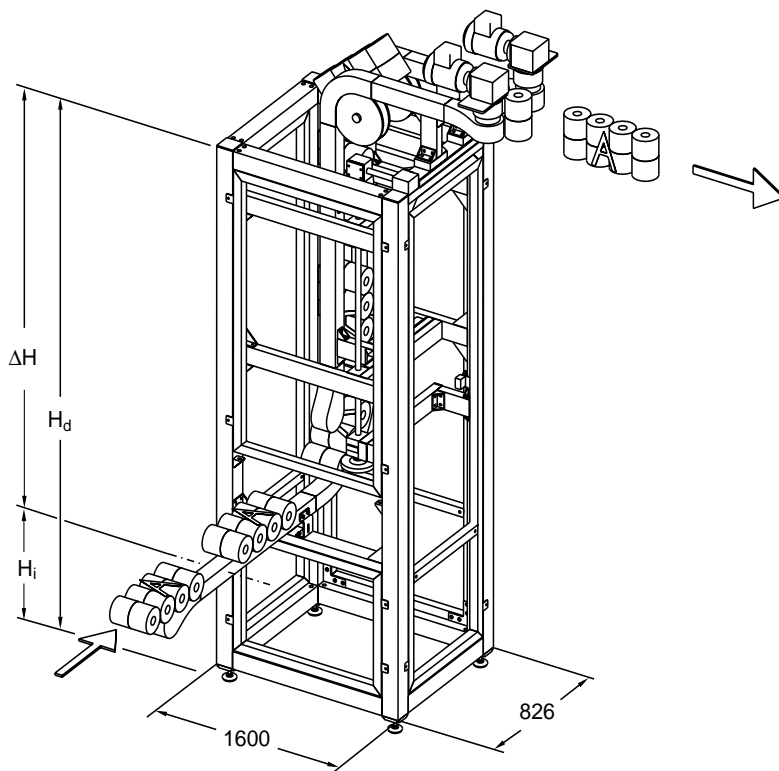

FlexLink is a leading supplier of automation solutions for manufacturing and assembly processes. The Paper Converting Centre of Excellence is a unit within FlexLink with specialists on product handling equipment for the tissue paper industry. We deliver systems for cost-efficient flow management at all stages of the converting operation, from the core to the finished product. Our extensive offer ranges from component deliveries to turn-key installations and pre-assembled modular units for the most common requirements.