

Pallet locating station, pallet stop and stop device, type A – XK

Contents

Pallet locating station and pallet stop, type A (1)

XKPX 175 A	2
XKPD 32×15 LA	3

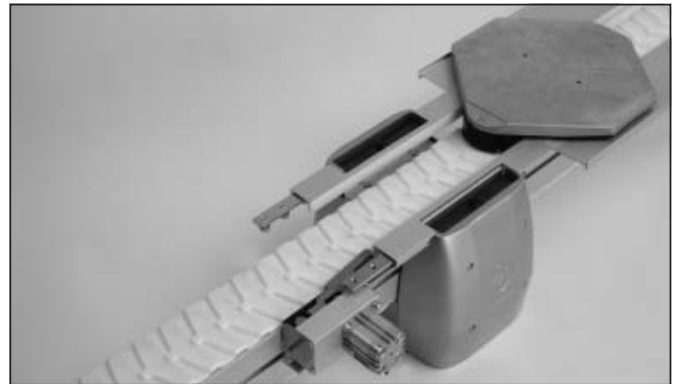

Pallet stop device, type A (2)

XKPD 32×15 A	4
Revision list	5



Pallet locating station and pallet stop, type A

XKPX 175 A

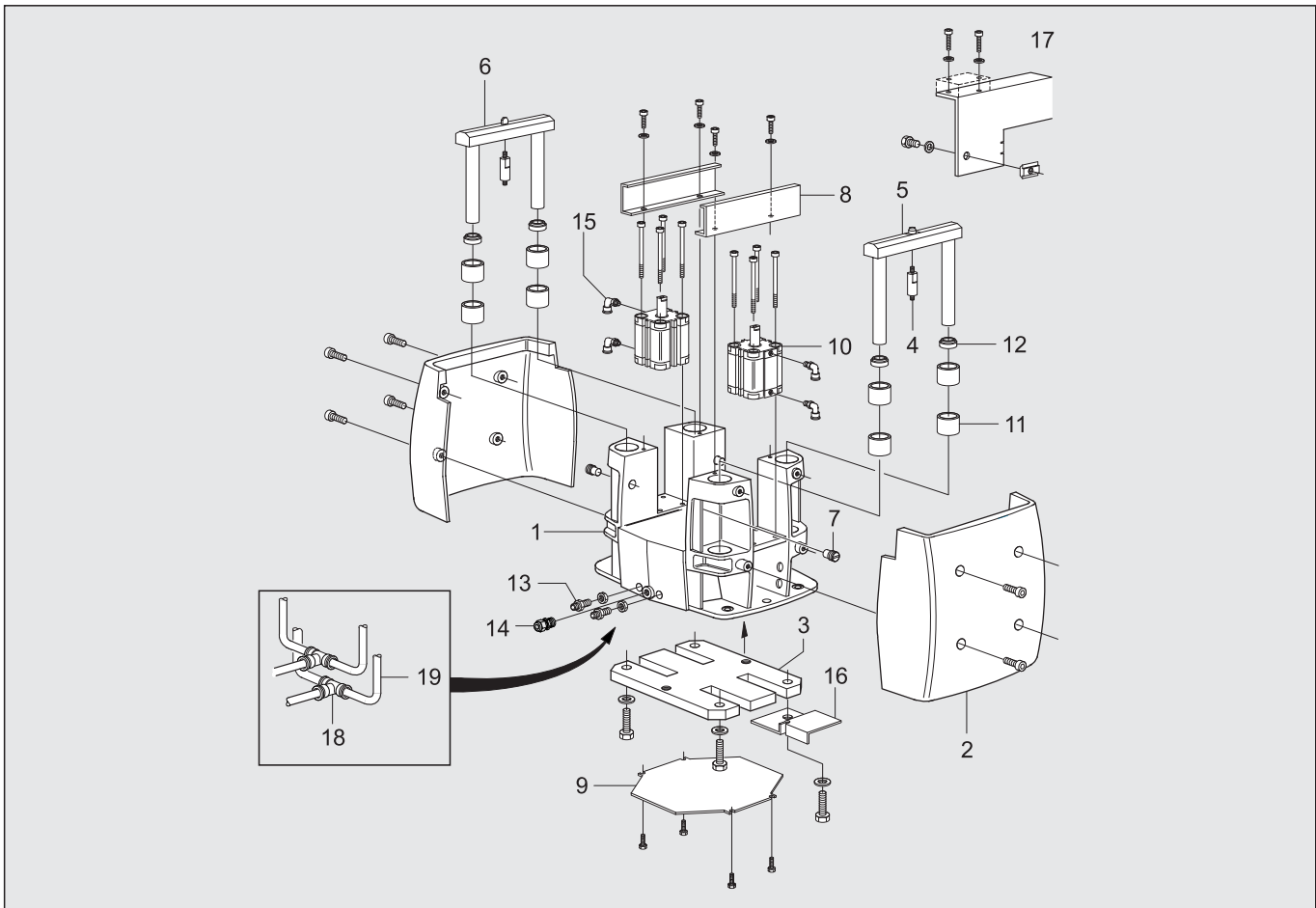

Item	Description	Part no.	Qty	Comments
1	Frame	3926590	1	
2	Cover	3926591	2	
3	Plate	3926593	1	
4	Axle peg	3926596	2	Loctite or similar
5	Ruler kpl	3927411	1	
6	Ruler kpl	3927412	1	
7	Guide screw	3926599	4	
8	Shield	5044839	2	
9	Cover	3927340	1	
10	Pneumatic cylinder	ADVU-40-25-P-A	2	
11	Bushing	777 25/30x20	8	
12	Rod wiper	25-35-7-10	4	
13	Bulkhead connector	QSMS-6	2	
14	Cable fitting	ELFA 55-019-60	1	PG 11
15	L-fitting	QSML-1/8-6	4	
16	Sensor plate	5044851	1	Incl. screws and washers
17	Attachment	5044799	1	Incl. screws and washers
18	T-connector	QSMT-6	2	
19	Plastic tubing	PUN-6x1	1	L=0,5 m

Pallet locating station and pallet stop, type A

XKPD 32x15 LA

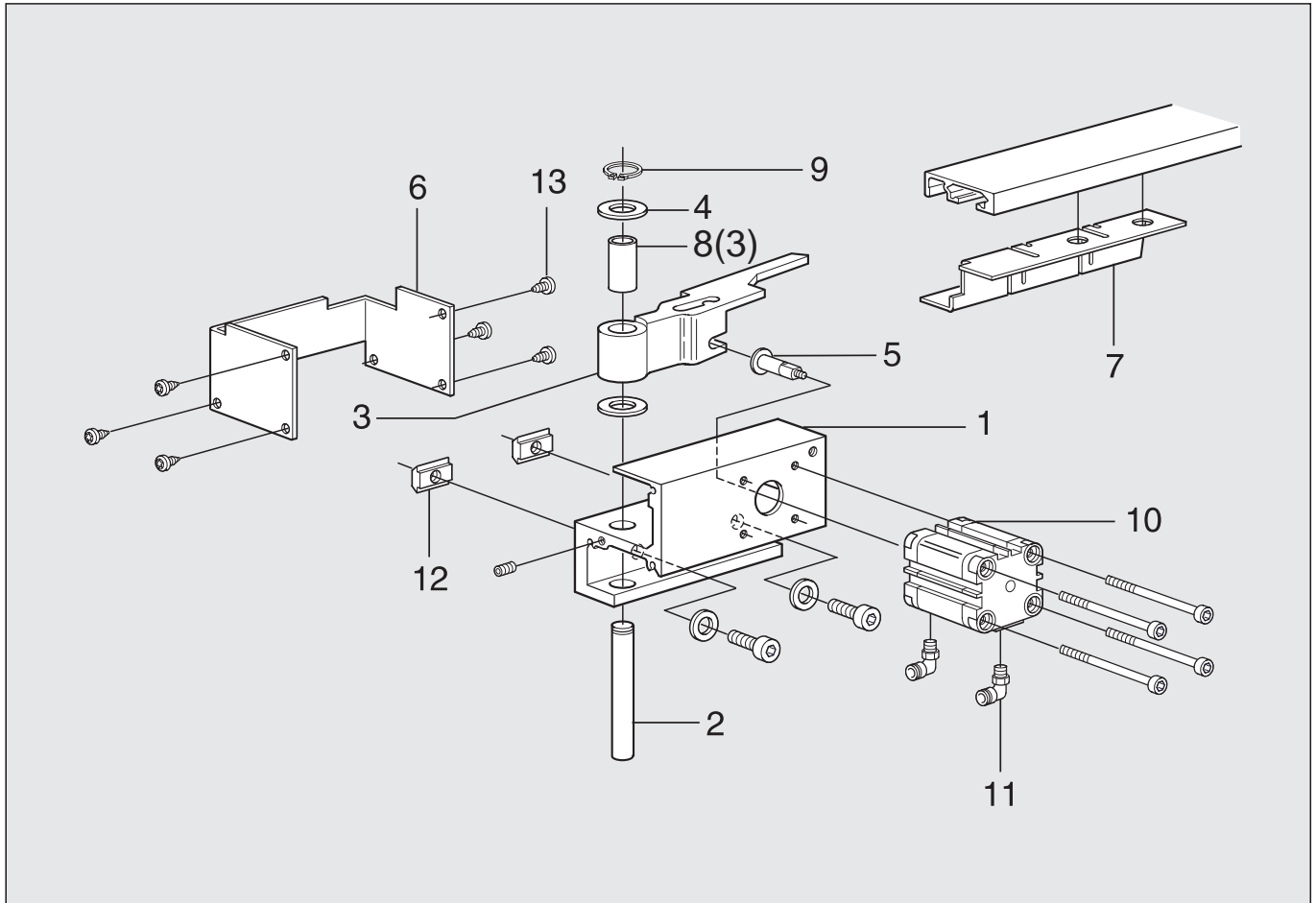

Item	Description	Part No.	Qty	Comments
1	Attachment	5044790	1	
2	Shaft	3926473	1	
3	Arm	3927339	1	Includes item 8
4	Washer	3926474	2	
5	Piston rod end	3921314	1	Loctite or similar
6	Cover	3927138	1	
7	Cover	3927137	1	
8	Radial bearing	GLY.PG 1618 25 F	1	See item 3
9	Retaining ring	SgA 16	1	
10	Pneumatic cylinder	ADVU 32-15-P-A	1	
11	L-fitting	QSML-1/8-6	2	
12	Slot nut	XCAN 8	2	
13	Screw	RXS-Z ST 4,2x6,5	6	Loctite or similar

Pallet stop device, type A

XKPD 32x15 A

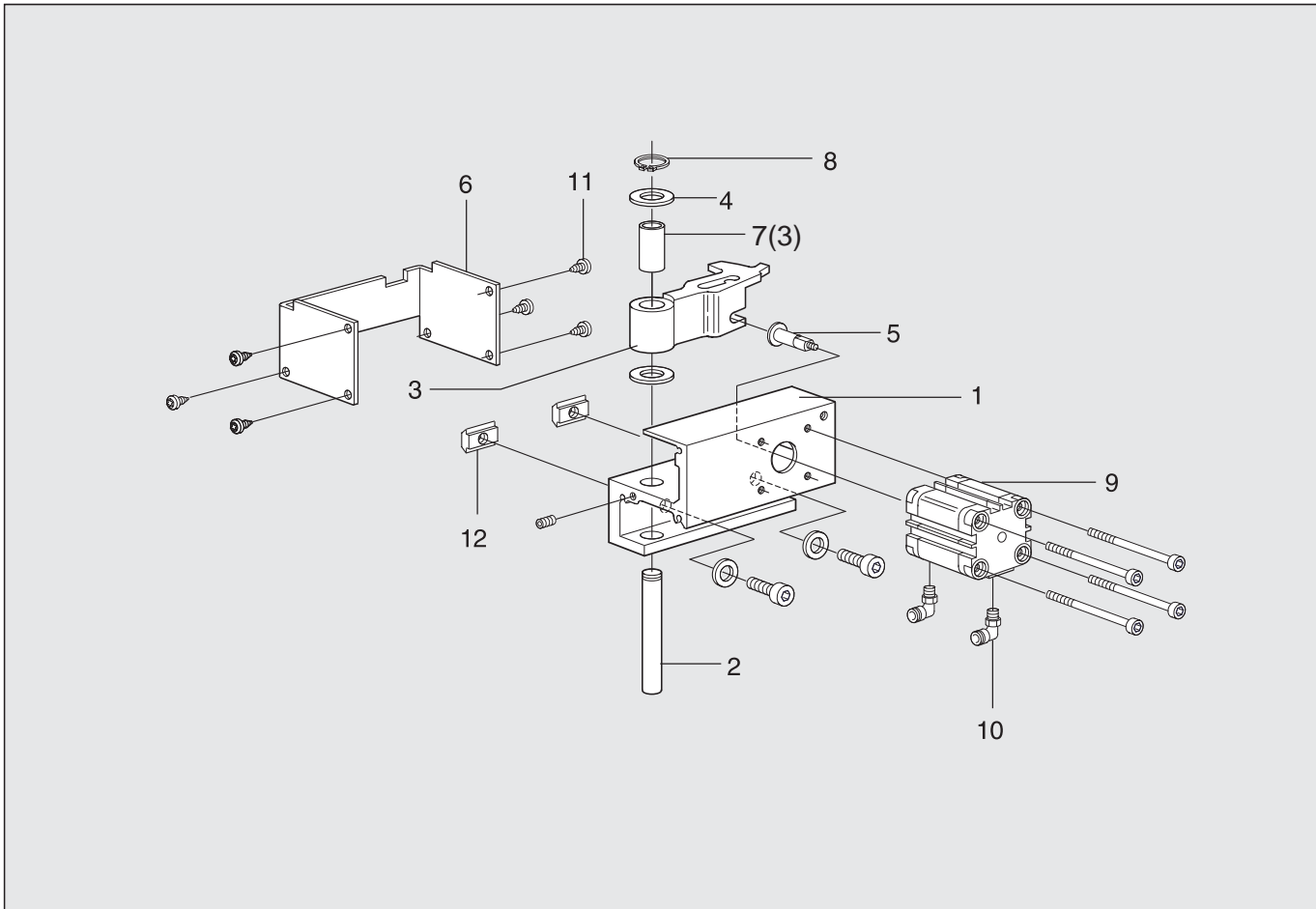

Item	Description	Part No	Qty	Comments
1	Attachment	5044790	1	
2	Shaft	3926473	1	
3	Arm	5053762	1	Includes item 7
4	Washer	3926474	2	
5	Piston rod end	3921314	1	Loctite or similar
6	Cover	3927002	1	
7	Radial bearing	GLY. PG 161825 F	1	See item 3
8	Retaining ring	SgA 16	1	
9	Pneumatic cylinder	ADVU 32-15-P-A	1	
10	L-fitting	QSML -1/8-6	2	
11	Screw	RXS-Z ST 4,2x6,5	6	Loctite or similar
12	Slot nut	XCAN 8	2	

Revision list

Document designation	Date	Type of revision	Entered by
PH006-E1	98-10-14	New version	Enator Inforum
PH006-E2	01-10-18	Item 3, page 4 - new part no	Kristina Lindén