

FS-30 Centrifugal Feeder

Designed for Quiet, High Speed Feeding

Product Overview:

Hoppmann's standard FS-30 scallop feeder is designed to feed and orient bottles and other cylindrical parts with the use of urethane scallops. Parts are radially oriented and gently qualified in the scallop pockets by means of sweeps, wipers, pneumatic and/or electric devices depending on specific product characteristics. Oriented parts are discharged and carried away by various downstream in-line devices.

Product Specifications:

	ANSI	Metric
A. Overall Outside Square	50.25"	1276mm
B. Frame Height	46"	1168mm
C. Bowl Height	36.25"	921mm
D. Bowl Outside Diameter	36.12"	917mm
E. Bowl Inside Diameter	28.80"	732mm
F. Rim Width	3.66"	93mm
G. Bowl Depth	3.98"	101mm
H. Level Foot Adjustment	4.63" ± 2"	118mm ± 51mm

Standard Models:

Part Number	FS301RLDSA	FS301RLASA
Motor Style	DC	AC
Motor Voltage	90V	230/460V
Horsepower	1/3 hp	1/8 hp

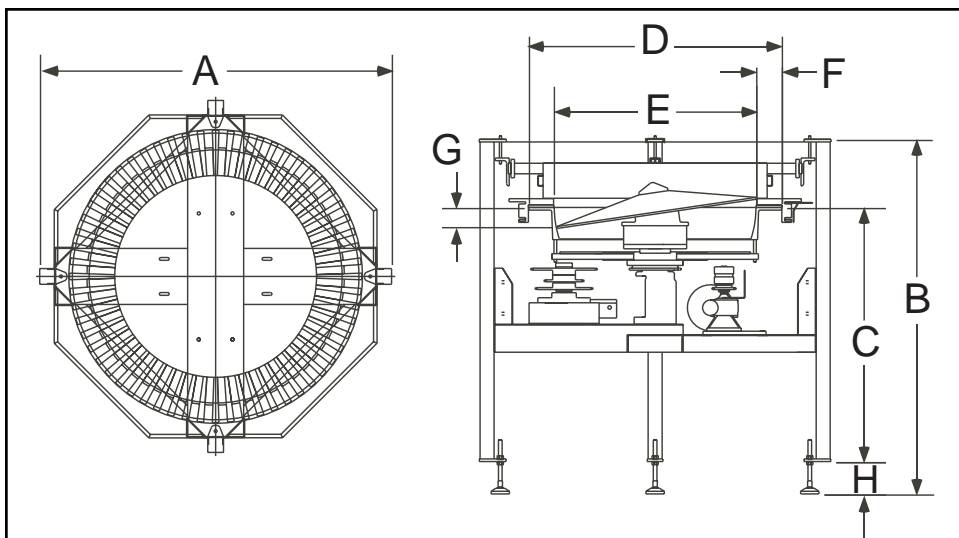

Standard Features:

- All stainless steel construction
- FDA/USDA approved heavy gauge ABS plastic disc
- Teflon hard-coat finished aluminium bowl, predrilled for scallop mounting
- Hinged polycarbonated cover with safety interlocks

Available Options:

- Washdown motors
- Mounted controller
- Mechanical style level sensor (proximity sensor not included)
- Urethane scallop kit