

## EP-35/18 & EP-50/18 Elevating Prefeeder

Designed for Floor Level Parts Loading

### Product Overview:

Hoppmann's standard EP-35/18 elevating prefeeder is designed to handle a variety of large, lightweight parts. Its thirty-five (35) cubic foot capacity hopper delivers product at an average belt speed of 23 feet per minute. The cleated elevator belt has a nominal cleat height of 3.00" and a cleat pitch of 12.00" allowing for maximum product loading. A heavy duty variable speed motor helps to ensure proper product metering.

### Product Specifications:

	ANSI	Metric
A. Overall Width	72"	1829mm
B. Overall Length	95"	2413mm
C. Lower Chassis Footprint	76.62"	1947mm
D. Dump Height (Adjustable)	45 - 58"	1143 - 1473mm
E. Hopper Load Height (35 cu. ft.)	45"	1143mm
Hopper Load Height (50 cu. ft.)	51"	1295mm
F. Belt Width	18"	457mm

### Standard Models:

Part Number	EP3518XDSA	EP3518XASA
Motor Style	DC	AC
Motor Voltage	90V	230/460V
Horsepower	1/2 hp	1/2 hp
Total Equipment Weight	1200 lbs.	1200 lbs.

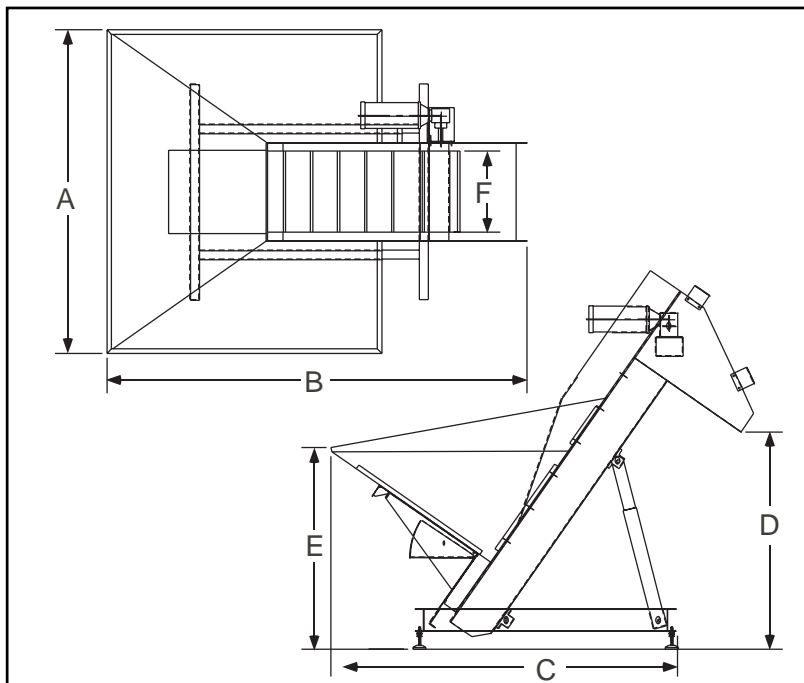

### Standard Features:

- All stainless steel construction
- Belting is FDA/USDA approved white 1-ply solid woven polyester fabric with 1/16" thick white PVC coating and PVC cleats
- Hopper cleanout door

### Available Options:

- Elevator extensions
- Continuous welded hopper seams
- Elevator/hopper covers
- Washdown motor
- Mounted controller
- Casters
- Hopper extension for 50 cubic foot capacity
- Mechanical style level sensor (proximity sensor not included)
- Modular plastic chain upgrade
- Pneumatic part agitator (hopper)