

Modular conveyor system EM



FlexLink®

FIRST CHOICE FOR EASIER AUTOMATION

Modular conveyor system EM – smart solutions for light applications

The EM conveyor is a plastic chain conveyor especially well suited for light applications in the packaging industry. The modular concept allows simplified engineering and ordering as well as reduced assembly time.

A modular system from FlexLink is effective, requires a minimum of maintenance and is easily adjustable to changing needs in the production process. The reliable and proven plastic chain technology together with advanced product development with speed and global presence, enables FlexLink to offer you the best return on your investment. Through world leading competence in profitable automation, we aim to be your first choice.

Modular design

The modular design is based on global application experience and reduces engineering and assembly time by offering functions instead of components. This enables a faster ordering process and quicker delivery, creating flexible layouts.

The compact design allows the conveyors to be easily connected to machines, and the conveyor modules can also be built together to form larger systems.

Short delivery time

The modules are delivered in pre-assembled sections, which are quick and easy to assemble, within one week after the order has been placed.

Technical specifications

Max. total conveyor length 8 m
 Max. conveyor speed 35 m/min
 Max. non-accumulated load see diagram below
 Max. accumulated load see diagram below
 Max. product weight 2 kg
 Max. working temperature 60°C

Will withstand lengthy contact with most chemicals. Avoid acids with pH lower than 4, bases above 9 and lengthy exposure to chlorinated hydrocarbons.

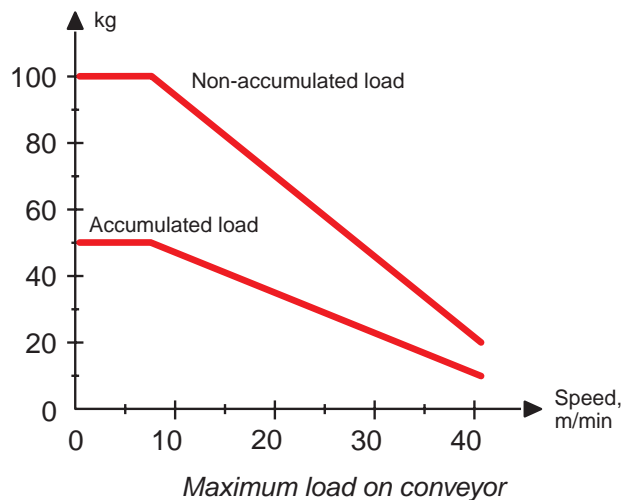

Chain

- Virtually maintenance free
- Table top design
- Safe
 - Plain chain only
 - Small gaps between links

Conveyor

- Curved chain on beam

Drive unit

- No chain slack
- Small motor
- Direct drive
- 50 or 60 Hz

Conveyor support

- Clean design
- Beam support mounted under conveyor beam
- Three point attachment to table with one bolt. Note! The conveyor can be bolted to start-up.
- ±15 mm height

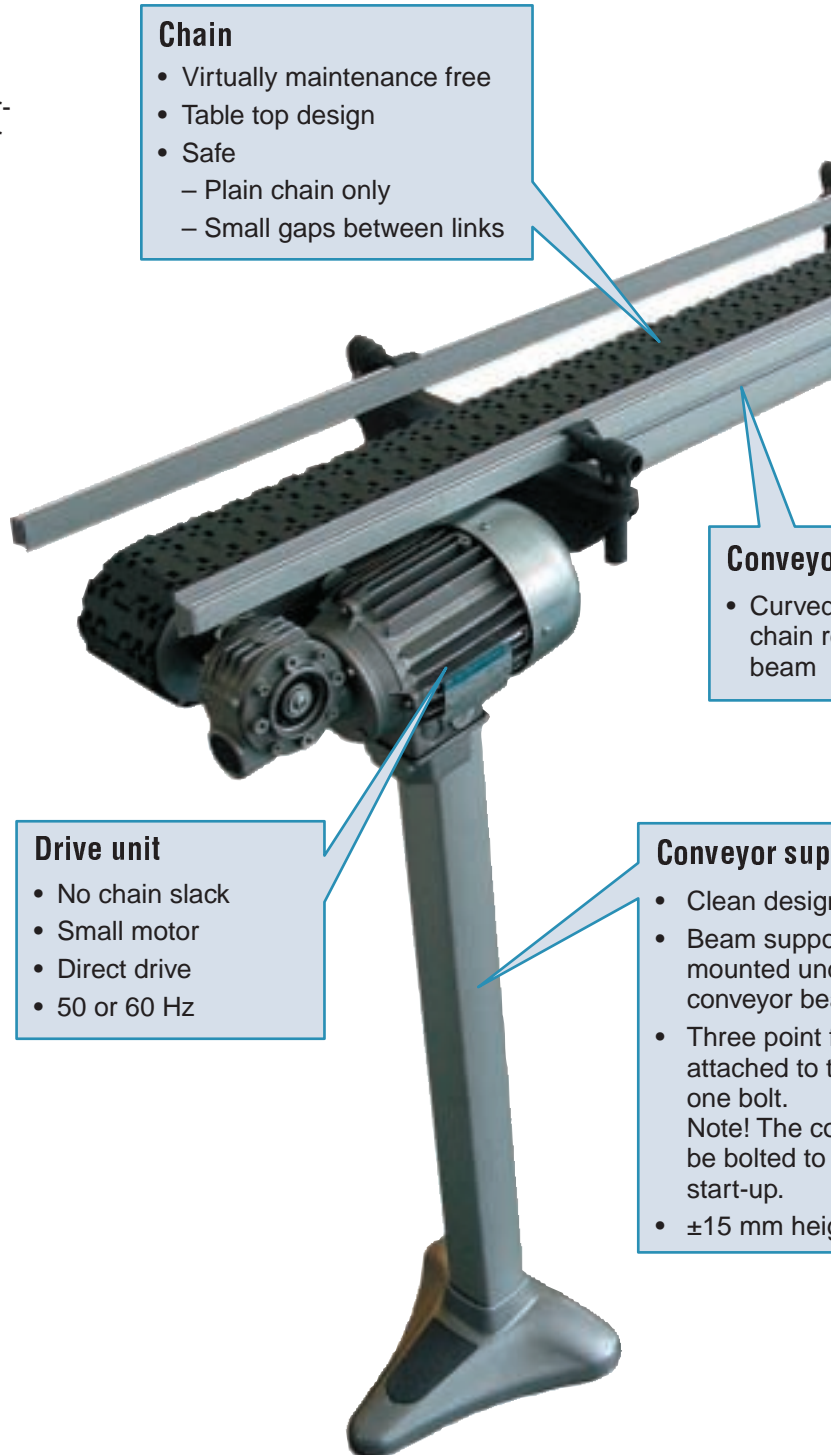

Slide rail

- Virtually maintenance free
- No elongation
- High wear resistance
- Good chemical resistance
- Good temperature resistance

Guide rails

- Available in widths up to 188 mm

Idler unit

- No chain slack

Support beam

Special design to allow easy return inside the conveyor

Supports

Adjustable support bracket underneath the beam
Support foot which is adjustable to the floor with
Height adjustment
The conveyor must be level with the floor before
Height adjustment

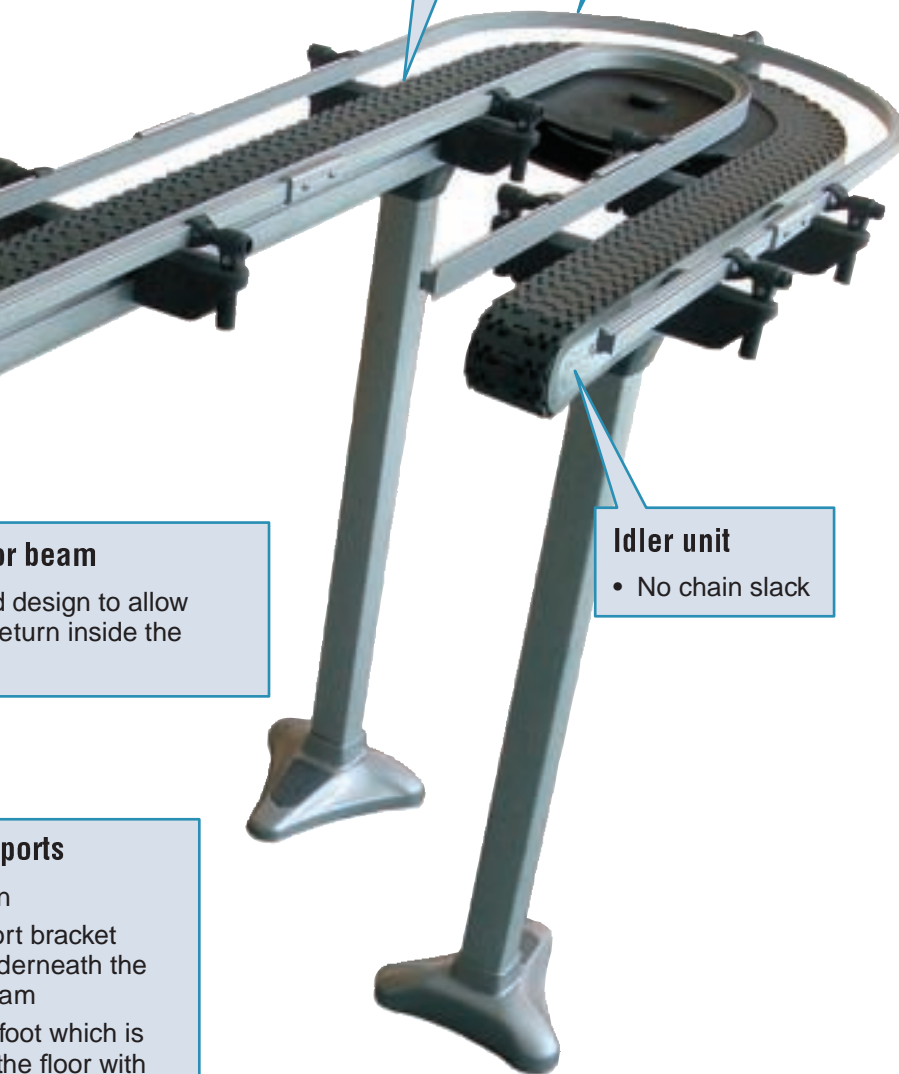

Parallel EM conveyor tracks transporting plastic bottles



In-feed of labeller for pharmaceutical products



Pharmaceutical bottles exiting blowing machine

Conveyor modules

Module S



Option S1

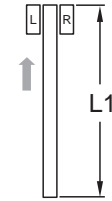

Minimum length, mm	
L1	739

Module L

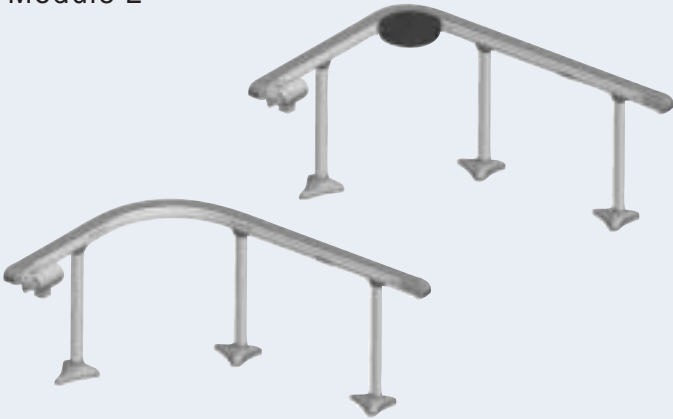

Option L1

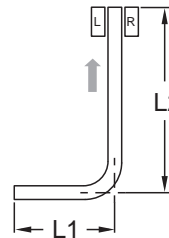

Option L2

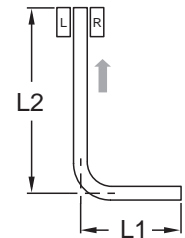

Minimum length	Plain bend			Wheel bend		
	30°	45°	90°	30°	90°	180°
L1 (mm)	773	846	1139	721	839	839
L2 (mm)	773	846	1139	721	839	839

Module U

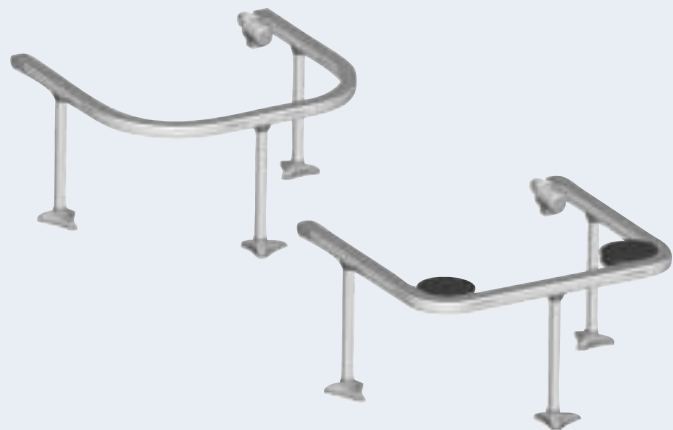

Option U1

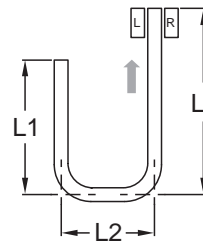

Option U2

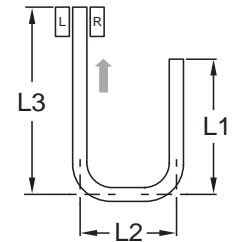

Minimum length*	Plain bend			Wheel bend		
	30°	45°	90°	30°	90°	180°
L1 (mm)	773	846	1139	721	839	839
L2 (mm)	613	759	1345	509	745	1688
L3 (mm)	773	846	1139	721	839	839

Module Z



Option Z1

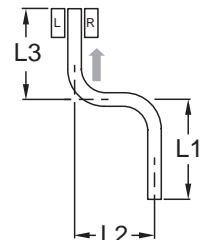

Option Z2

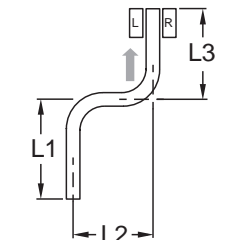

Minimum length*	Plain bend			Wheel bend		
	30°	45°	90°	30°	90°	180°
L1 (mm)	773	846	1139	721	839	839
L2 (mm)	613	759	1345	509	745	745
L3 (mm)	773	846	1139	721	839	839

All examples on this page show 90° bends. See pages 6–7 for other options.
 * These min. lengths are valid only if both bends are of the same type and angle.

Guide rail configurations

Type 1

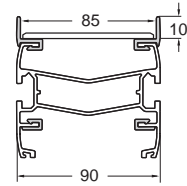
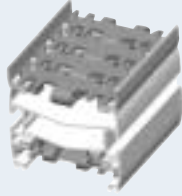

Only available on straight module type S1.

Type 2

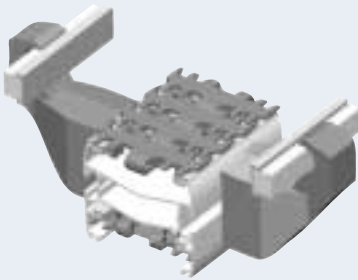

- $W_1 = 100 \text{ mm}$
- $W_2 = 112 \text{ mm}$
- $W_3 = 124 \text{ mm}$
- $W_4 = 136 \text{ mm}$
- $W_5 = 148 \text{ mm}$
- $W_6 = 160 \text{ mm}$
- $W_7 = 172 \text{ mm}$

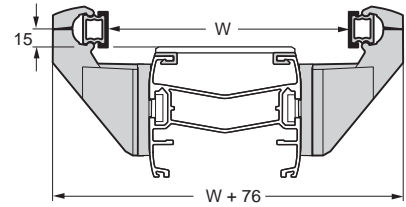

Type 3

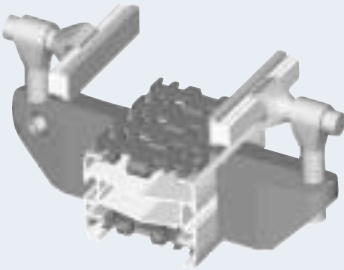

- $WH_{\min} = 16 \text{ mm}$
- $WH_{\max} = 35 \text{ mm}$
- $W_1 = 12-92 \text{ mm}$
- $W_2 = 48-128 \text{ mm}$
- $W_3 = 84-164 \text{ mm}$

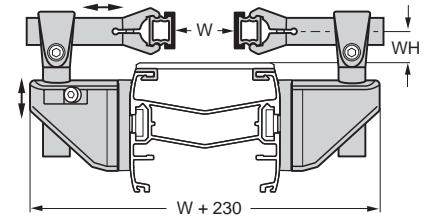

Type 4

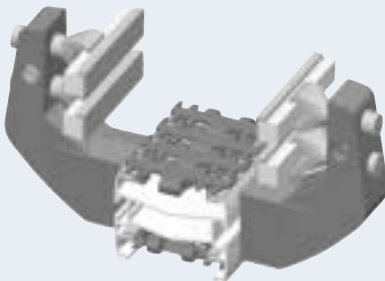

- $W_1 = 36-116 \text{ mm}$
- $W_2 = 72-152 \text{ mm}$
- $W_3 = 108-188 \text{ mm}$

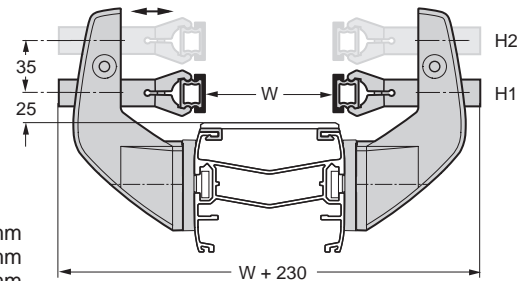

Type 5

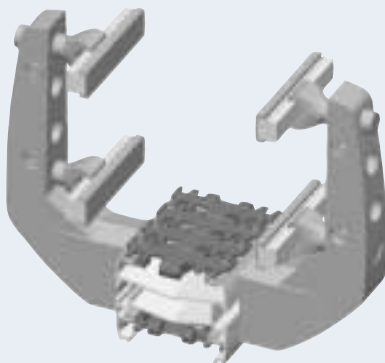

- $W_1 = 36-116 \text{ mm}$
- $W_2 = 72-152 \text{ mm}$
- $W_3 = 108-188 \text{ mm}$

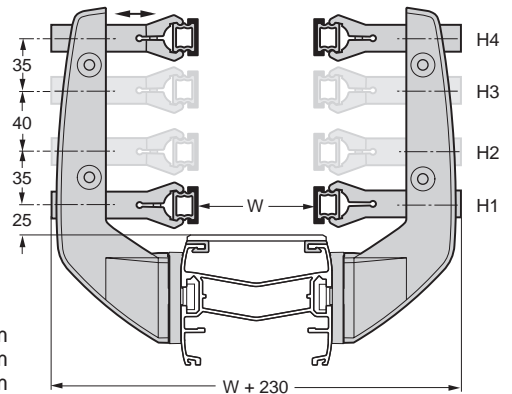

The c/c distance between guide rail brackets is always $\leq 600 \text{ mm}$.
Guide rail covers and dummy plugs are included.

Module configuration examples

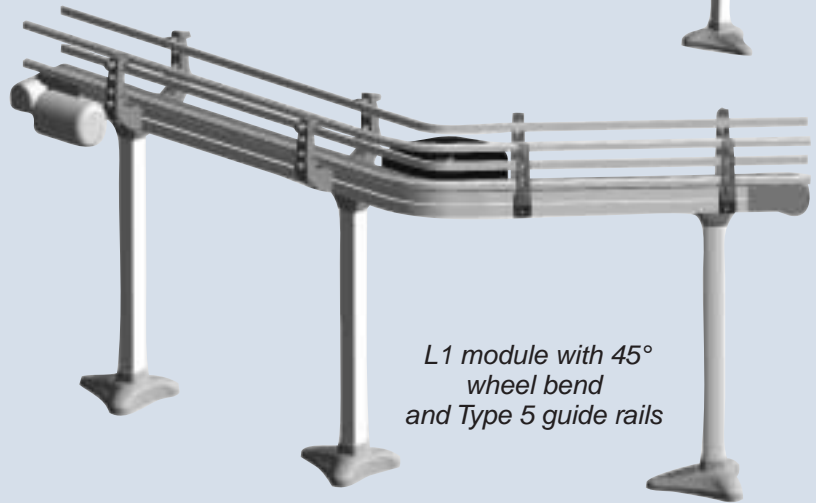
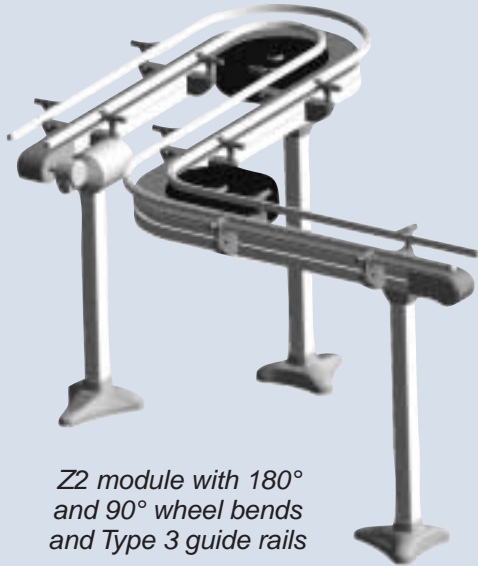

Mounting dimensions

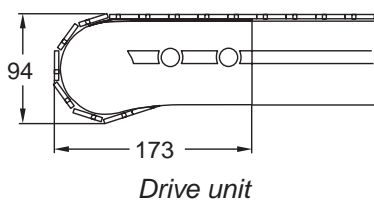
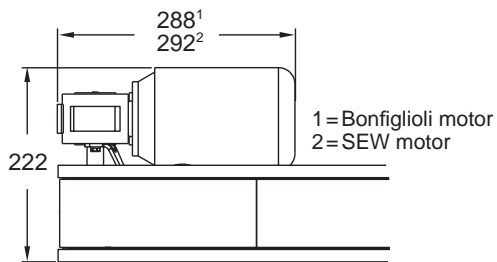
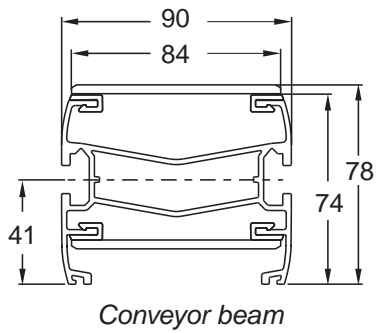

Ordering dimensions

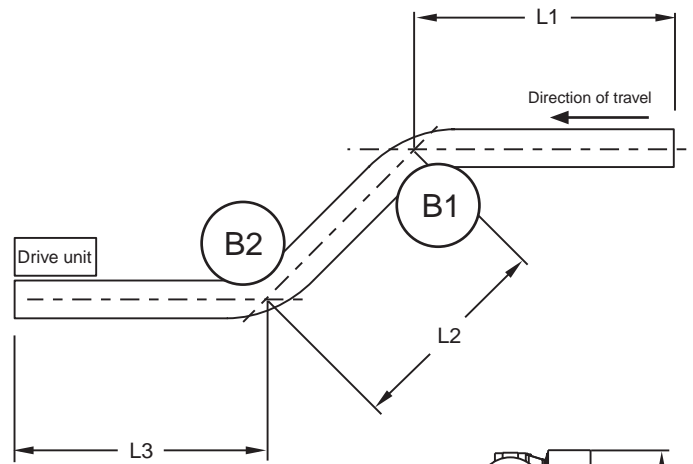

- L1 = Length from idler end to centre of B1
- L2 = Length from centre of B1 to centre of B2
- L3 = Length from centre of B2 to drive unit end
- B1 = Bend closest to idler end
- B2 = Bend closest to drive end

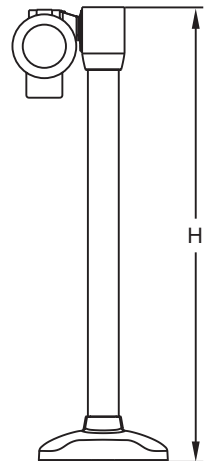

EM conveyor module

Quotation request Order

Company name	
Contact person	
Department	
Address	
Phone	Fax
E-mail	

Please copy this page and fax it to your local FlexLink representative (see back). Use one copy per module configuration.

Product data

Product description: _____

Material: _____

Product weight (max. 2 kg): _____ kg

Max. number of products on conveyor
(max. accumulated weight 50 kg): _____

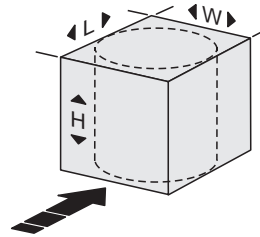

L: _____ mm

W: _____ mm

H: _____ mm

Conveyor data

Module: S1 L1 L2 U1 U2 Z1 Z2

Number of modules: _____

Lengths: (L1 + L2 + L3 = max. 8 m)

L1 = _____ mm L2 = _____ mm L3 = _____ mm

Bend type:

B1 plain bend (R=500 mm) 30° 45° 90°
 wheel bend (R=200 mm) 45° 90° 180°

B2 plain bend (R=500 mm) 30° 45° 90°
 wheel bend (R=200 mm) 45° 90° 180°

Bonfiglioli motor, standard speeds:

50 Hz (m/min): 5 8 11 17 23 35

60 Hz (m/min): 6 11 14 21 28 41

SEW motor, standard speeds:

50 Hz (m/min): 5 8 11 16 22 31

60 Hz (m/min): 6 12 16 21 29 39

Motor position: L R



Guide rail type: 1 2 3 4 5
 None

W, mm: W₁ W₂ W₃ W₄ W₅ W₆ W₇

Width between guide rails (types 3, 4, 5): _____ mm

WH _____ mm (type 3)

Position (types 4, 5): H1 H2 H3 H4

Number of supports/module: _____

Height: _____ mm

Recommended distance between conveyor supports: 2–3 metres.

Delivery date: _____

Appendixes: _____

Date

Signature