

Conveyor beams

Type XS, XL, XM, XH, XK

Aluminium beam profiles

FlexLink conveyors are based on aluminium beam profiles. Systems XS, XL, XM, XH, and XK are single profile beams, whereas system XB beams consist of a single profile in the middle, with side profiles on each side, to create a wider conveyor.

Conveyor beam XS, XL, XM

The chain track for straight conveyor sections is delivered as beam stock to be cut as required.

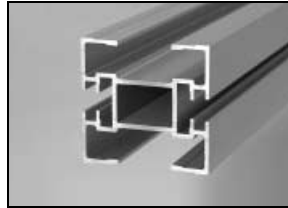

Conveyor beam XH

The chain track for straight conveyor sections is delivered as beam stock to be cut as required. Two conveyor beam versions are available – standard (sufficient in most applications) and reinforced (R).

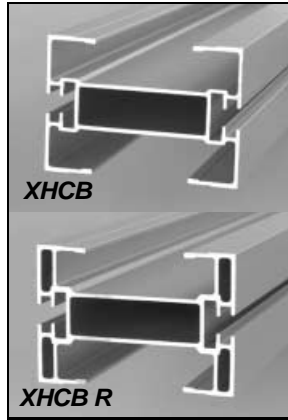

Conveyor beam XK

The chain track for straight conveyor sections is delivered as beam stock to be cut as required. Conveyor beam XKCB is normally used.

Conveyor beam XKCB type N can be used for track sections where it should be possible to lift the chain out of the beam to facilitate cleaning, etc. See figure.

Conveyor beam XKCB type N can be joined only to the ordinary XKCB beam or to the plain bend XKBP.

Conveyor beam type N must not be used in applications where the conveyor beam has an inclination from the horizontal plane.

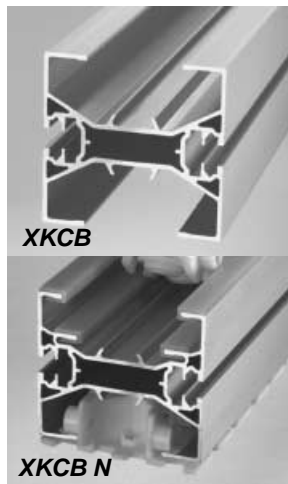

Technical specifications

Point load F + beam weight + weight of two-way chain for 10 mm deflection, see illustration:

Conveyor systems	F (N)	Beam deflection from straight line
XS	200	
XL	390	
XM	550	
XH standard	590	
XH reinforced	800	
XK	1200	

Slide rails

Slide rail products: see page 63.

Plastic slide rail is used to provide a low-friction track for the chain. Slide rail is available in four plastic materials: HDPE, PVDF, UHMW-PE, and PA-PE, and in acid resistant stainless steel, see table.

HDPE slide rail is suitable for most standard applications. In environments where high resistance to chemicals is important, PVDF slide rail is recommended.

PA-PE and UHMW-PE slide rail is best suited for high speed applications, high accumulation loads, or where cleanliness is important. See “Considerations when selecting slide rail” on page 41.

Slide rail made of acid resistant stainless steel is available in 3 m straight lengths. It is intended for high wear applications. (Use PVDF slide rail in bends.)

Plastic screws or aluminium rivets are used to fix the slide rail to the beam, see table. See “Anchoring the slide rail” in Appendix A, page 388.

Note: When using UHMW-PE slide rails and the calculated load from a product exceeds 20 N for a single chain link, always use plastic screws every meter of the slide rail. See “Considerations when selecting slide rail” on page 41.

Installation of slide rail on XKCB N: See “Slide rail installation – conveyor beam XKCB N” in Appendix A, page 390.

	XS	XL	XM	XH	XK	XB
Slide rail						
HDPE ¹	x	x	x	x		x
PVDF ²	x	x	x	x	x	
UHMW-PE ³	x	x	x	x	x	
PA-PE ⁴		x	x	x		
Steel S ⁵		x	x	x		
Plastic screw						
XLAG 5	x	x	x	x		x
XWAG 5					x	
Aluminium rivet						
XLAH 3x6	x					
XLAH 4x6		x	x	x		
XLAH 4x7					x	x

1 High density polyethylene (no suffix in designation)

2 Polyvinylidene fluoride (suffix P in designation)

3 Ultra-high molecular weight polyethylene (suffix U in designation)

4 Polyamide-polyethylene (suffix H in designation)

5 Stainless steel (suffix TA in designation)

Tools and accessories (XB see next page)

Installation tools for slide rail

Special tools are available for installation of the slide rail. See page 64. Also see Appendix A, page 386, where installation of the slide rail is described.

T-slot cover strip

A snap-fit cover strip is available to cover the T-slots in the beam. See page 65.

Connecting strips

The beams are joined together by means of connecting strips. Normally, the longer strips should be used when two lengths are available. Connecting strips are listed on page 65.

Beam section

A beam section can be used to simplify chain installation. The beam section is open on one side, so that the chain can be installed. After installation of the chain, the removable chain guides are returned and secured by means of screws. (See Appendix C, page 393.)

Beam spacer

The beam spacer is used to connect two conveyor beams side to side. Assembly: cut the beam spacer to the desired length. Connect using M8 screw and slot nut. Two holes must be drilled: one through the spacer beam (9 mm), and one in one of the beams to allow insertion of the screw. The diameter of the second hole depends on the size of the screw head. See figure.

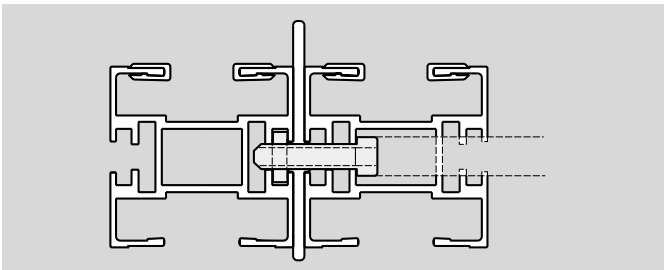

Tools and accessories – overview

	XS	XL	XM	XH	XK
T-slot cover strip					
Plastic	x	x	x	x	x
Aluminium					x
Connecting strips					
130 mm	x	x	x	x	
160 mm		x	x	x	x
Beam section					
160 mm		x	x	x	
200 mm					x

Ordering information (XB see next page)

- 1 Determine the number of beam lengths/sections required. Beams can be delivered in 3 m and 6 m lengths, and precision cut to any length up to 6 m.
- 2 Determine the length of slide rail required. Four lengths of slide rail are normally required for each length of track, if the chain returns via the bottom of the beam.

Note for XK: XKCB type N requires six slide rail lengths.

Do not forget bends, drive units etc. The effective track length of each such component is specified in the table “Effective track lengths” in “Conveyor engineering guidelines”.

- 3 Estimate the required number of plastic screws or aluminium rivets for the slide rail. Two screws/rivets are required for each separate piece of slide rail. The screws/rivets must be ordered separately. The quantity must be specified in multiples of 50 (plastic screws) or in multiples of 250 (rivets).
- 4 Determine the number of connecting strips required. Two connecting strips are required for each joint between straight beam sections.

The connecting strips must be ordered separately. Note! Bends, drive units, etc. are delivered with the necessary connecting strips.

Conveyor beams – overview (XB see next page)

Product	XS	XL	XM	XH	XK
	Beam width 45 mm Beam height 65 mm	65 mm 65 mm	85 mm 75 mm	105 mm 75 mm	105 mm 95 mm
Conveyor beam, standard	XSCB * Page 60	XLCB * Page 60	XMCB * Page 60	XHCB * Page 61	XKCB * Page 61
Conveyor beam reinforced				XHCB * R Page 61	
Conveyor beam Type N					XKCB * N Page 61
Articulated beam section (vertical)		XLCH 5 V Page 66			

Type XB

Conveyor beam XB

The chain track for straight conveyor sections consists of a middle section similar in size to the XM beam, with separate half-section beams attached on the sides to obtain the desired width (182 mm/300 mm). Straight sections up to 3 m can be delivered assembled (XB 175 version), in kit form (XB 295 version), or as unassembled parts.

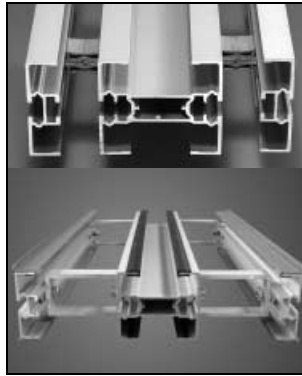

Technical specifications XB

Beam deflection under load

Point load F + beam weight + weight of two-way chain for 4 mm deflection (see illustration):

$$F = 1200 \text{ N}$$

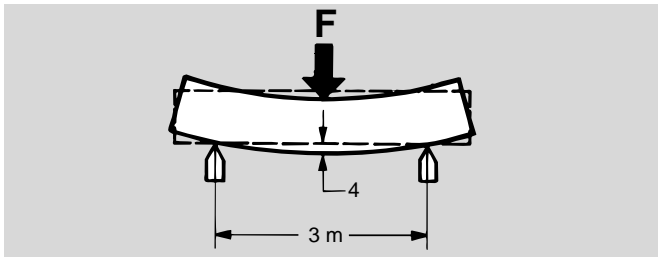

Beam deflection from straight line

Tools and accessories XB

The beam sections are joined together to the desired length by means of four connecting strips at each joint. For easy assembly, the two middle strips should extend 10 mm further out from the beam than the outer strips. Only the outer strips need to be secured at both ends.

The outer beam half-sections are attached to the middle section using snap-fit aluminium clips (XB 175 version) or aluminium spacers (XB 295 version). A special tool (3923518) is required for fitting the clips with precision. Clips or spacers must be used minimum every 0,5 m.

A special tool for the installation of slide rail (XBMR 170) is available. A snap-fit plastic or aluminium cover strip is available to cover the T-slots in the beam.

Plastic screws or aluminium rivets are used to fix the slide rail to the beam, see table on page 57. See "Anchoring the slide rail" in Appendix A, page 388.

Beam section XBCC 300A can be used to simplify chain installation. This 300 mm beam section can be opened on one side, so that the chain can be installed. After installation of the chain, the removable chain guides are returned and secured by means of screws (see Appendix C, page 393).

Ordering information

- 1 Determine the number of beam sections required. Straight beam sections can be delivered in assembled sections up to 3 m (XB 175 version), in kit form (XB 295 version), or as unassembled parts. Order a sufficient number of clip kits or spacers to allow for a maximum distance of 0,5 m between clips/spacers.
- 2 Determine the length of slide rail required. If XBCR 25 is used, six lengths of slide rail are normally required for each length of track – four on the top side and two on the bottom side (middle section). If XBCR 25 is used in combination with XBCR _ UA, four lengths of regular slide rail and two lengths of slide rail for the upper outer beam sections are normally required. Do not forget bends, drive units etc. The effective track length of each such component is specified in the table "Effective track lengths" in "Conveyor engineering guidelines". Note that an extra length of slide rail is used in bends. See page 104
- 3 Estimate the required number of plastic screws or aluminium rivets for the slide rail. Two screws/rivets are required for each separate piece of slide rail. The screws/rivets must be ordered separately. The quantity must be specified in multiples of 50 (plastic screws) or in multiples of 250 (rivets).
- 4 Determine the number of connecting strips required. Four connecting strips must be ordered separately for each joint between straight beam sections. (Bends, drive units, etc. are delivered with the necessary connecting strips.)

Conveyor beams – overview XB

Product	XB 175	XB 295
	Beam width 182 mm Beam height 75 mm	300 mm 75 mm
Conveyor beam section (assembled)	XBCB *A175 Page 62	–
Conveyor beam section (unassembled kit)	–	XBCB *A295 Page 62
Conveyor beam (mid-section)	XBCB *A85 Page 62	XBCB *A85 Page 62
Conveyor beam (outer section)	XBCB *A H Page 62	XBCB *A H Page 62

Beam XS

Conveyor beam

XS

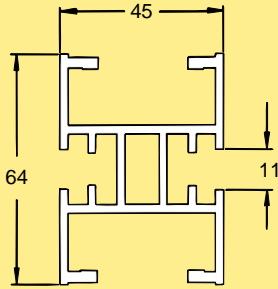

Beam

Length 3 m

Length 6 m

Length to order

XSCB 3

XSCB 6

XSCB L

Slide rail: see page 63

Beam accessories: see page 65

Beams XM

Conveyor beam

XM

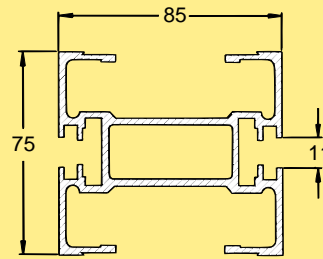

Beam

Length 3 m

Length 6 m

Length to order

XMCB 3

XMCB 3

XMCB L

Slide rail: see page 63

Beam accessories: see page 65

Beams XL

Conveyor beam

XL

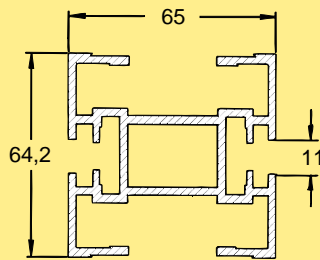

Beam

Length 3 m

Length 6 m

Length to order

XLCB 3

XLCB 6

XLCB L

Slide rail: see page 63

Beam accessories: see page 65

Beam section for chain installation

XM

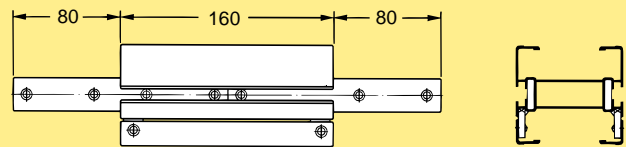

Beam section for chain installation

XMCC 160

Including connection strips and screws

Beam section for chain installation

XL

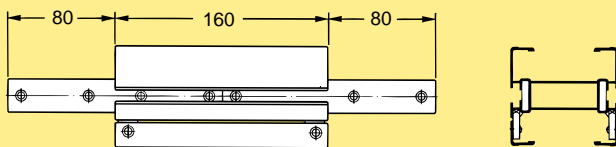

Beam section for chain installation **XLCC 160**

Including connection strips and screws

Beams XH

Conveyor beam

XH

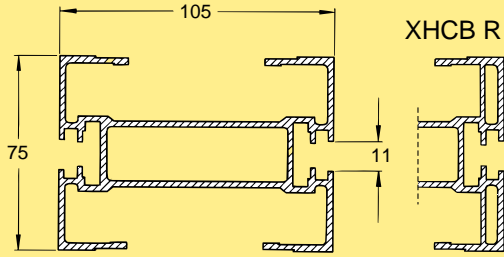

Beam

Length 3 m
Length 6 m
Length to order

XHCB 3
XHCB 6
XHCB L

Beam, reinforced

Length 3 m
Length 6 m
Length to order

XHCB 3 R
XHCB 6 R
XHCB L R

Slide rail: see page 63

Beam accessories: see page 65

Beam section for chain installation

XH

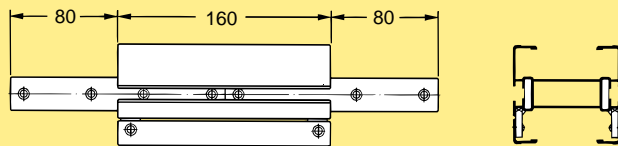

Beam section for chain installation **XHCC 160**

Including connection strips and screws

Beams XK

Conveyor beam, standard

XK

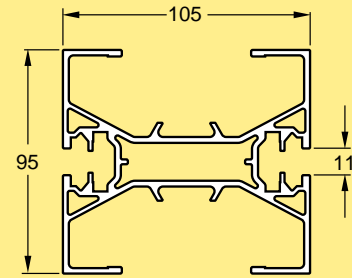

Beam, standard

Length 3 m
Length 6 m
Length to order

XKCB 3
XKCB 6
XKCB L

Slide rail: see page 63

Beam accessories: see page 65

Conveyor beam, Type N

XK

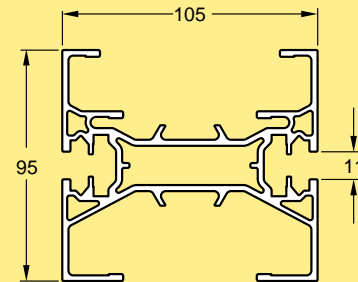

Beam, Type N

Length 3 m
Length 6 m
Length to order

XKCB 3 N
XKCB 6 N
XKCB L N

Beam accessories: see page 65

Beam section for chain installation

XK

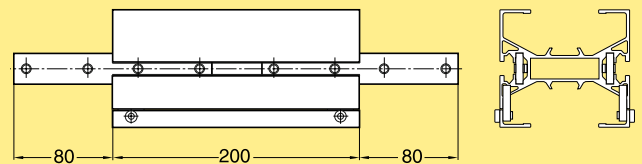

Beam section for chain installation **XKCC 200**

Including connection strips and screws

Beam components XB

Beam section (XB 175 version) XB

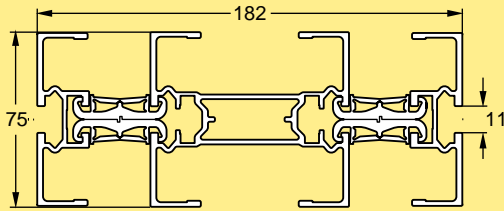

Beam section (assembled)
Length 3 m
Length to order (0,5–3 m)

XBCB 3A175
XBCB LA175

Slide rail: see page 63

Clip kit for outer beam sections XB

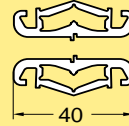

Snap-fit clip kit for outer beam sections

XBCE 40

Each kit contains two clips. For construction of 182 mm wide beam sections. Mounting tool: see below. Maximum distance between clips is 0,5 m.

Beam section kit (XB 295 version) XB

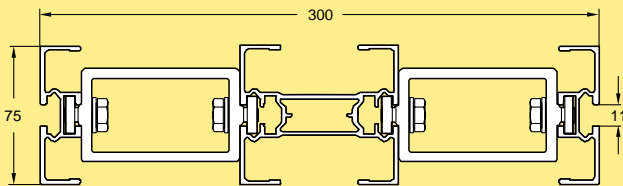

Beam section kit
Length 3 m
Length to order (0,5–3 m)

XBCB 3A295
XBCB LA295

The beam section is delivered unassembled.
Slide rail: see page 63

Spacer for outer beam sections XB

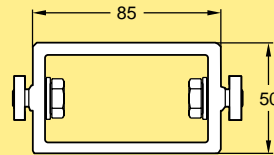

Spacer, aluminium

XBCE 85

Including screws and nuts. For construction of 300 mm wide beam sections. Maximum distance between spacers is 0,5 m.

Mounting tool for clip kit XB

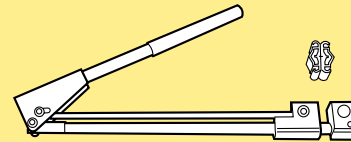

Mounting tool for aluminium clip kit
XBCE 40

3923518

Beam (mid-section) XB

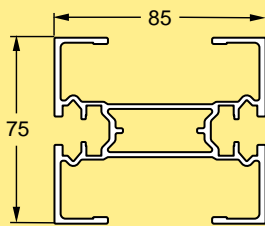

Beam (mid-section)
Length 3 m
Length to order

XBCB 3A85
XBCB LA85

Beam section for chain installation XB

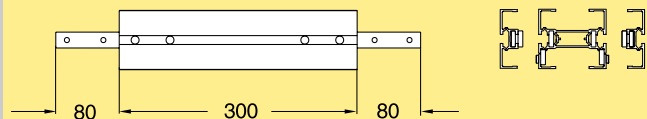

Beam section for chain installation

XBCC 300A

Including connection strips and screws

Beam (outer section) XB

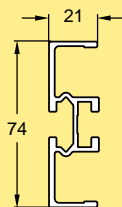

Beam (outer section)
Length 3 m
Length to order

XBCB 3A H
XBCB LA H

Slide rails

Plastic slide rails for XS beam **XS**

Slide rail
 Length 25 m
 Polyethylene
 PVDF
 UHMW-PE
 PA-PE

XSCR 25
XSCR 25 P
XSCR 25 U
XSCR 25 H

Plastic slide rail for XB beam, outer **XB**

Slide rail, outer
 UHMW-PE
 Length 3 m
 Length 6 m

XBCR 3 UA
XBCR 6 UA

Plastic slide rails for XL, XM, XH beams

Slide rail
 Length 25 m
 Polyethylene
 PVDF
 UHMW-PE
 PA-PE

XLCR 25
XLCR 25 P
XLCR 25 U
XLCR 25 H

Steel slide rail for XL, XM, XH beams

Slide rail
 Length 3 m
 Acid resistant stainless steel

XLCR 3 TA

Plastic slide rails for XK beams **XK**

Slide rail
 Length 25 m
 PVDF
 UHMW-PE
 PA-PE

XWCR 25 P
XKCR 25 U
XKCR 25 H

Plastic slide rail for XB beam **XB**

Slide rail
 Length 25 m
 Polyethylene

XBCR 25

Installation of slide rails

See installation instructions in Appendix A, page 386, or in the separate *Conveyor assembly manual*.

Slide rail tools and accessories

Mounting tool for slide rail

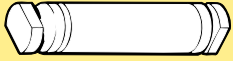

Mounting tool for slide rail

XS, XL
XM
XH
XK

XLMR 140
XMMR 140
XHMR 200
XKMR 200

Rivet crimping pliers



Rivet crimping pliers

XS, for 3 mm rivets
XL-XM-XH-XK-XB, for 4 mm rivets

3924776
5051395

Mounting tool for slide rail, XB

XB

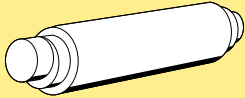

Mounting tool for slide rail

XBMR 170

Rivet crimping clamp

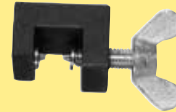

Rivet crimping clamp

XS, for 3 mm rivets
XL-XM-XH-XK-XB, for 4 mm rivets

3924770
3923005

Drill fixture for slide rail

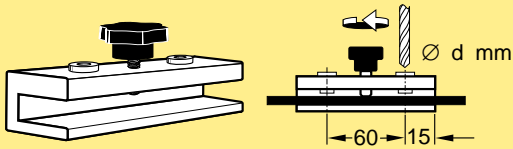

Drill fixture for slide rail

XS: d=3,2
XL-XM-XH-XK-XB: d=4,2

3924774
3920500

Plastic screws for slide rail

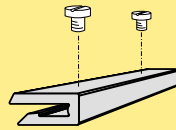

Plastic screws for slide rail
XS-XL-XM-XH-XB: 5 mm
XK: 5 mm

XLAG 5
XWAG 5

Note. Must be ordered in multiples of 50

Aluminium rivets for slide rail



Aluminium rivets for slide rail

XS: 3 mm
XL-XM-XH: 4 mm
XK-XB: 4 mm, brown

XLAH 3x6
XLAH 4x6
XLAH 4x7

Extra slide rail in plain bends must be anchored using plastic screws due to lack of space for the rivet crimping tool.

Note. Must be ordered in multiples of 250.

Beam accessories

Connecting strip with set screws

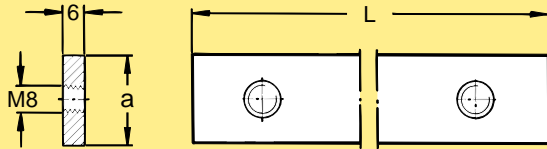

Connecting strip with set screws

XS: a=20, L=130

XL-XM-XH: a= 25, L=130

XL-XM-XH-XK: a= 25, L=160

XB: a=20, L=160

XSCJ 6×130

XLCJ 6×130

XLCJ 6×160

XSCJ 6×160

Note. Must be ordered in multiples of 10

Cover strip for T-slot, PVC

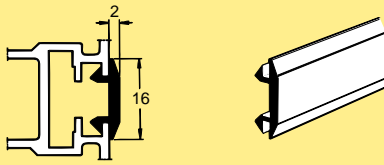

Cover strip for T-slot, PVC

Length 25 m

XLAB 25

For XS-XL-XM-XH

Cover strip for T-slot, PVC

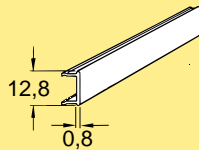

Cover strip for T-slot, PVC

Length 3 m

Grey

Yellow

XCAC 3 P
XCAC 3 PY

For XK-XB

Cover strip for T-slot, aluminium

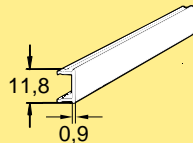

Cover strip for T-slot, aluminium

Aluminium, anodized

Length 2 m

XCAC 2

For XK-XB

Beam spacer

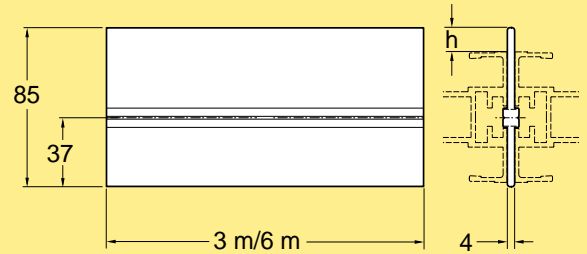

XS	XL	XM/XH	XK
h=16,0 mm	h=15,9 mm	h=10,5 mm	h=0,5 mm

Beam spacer

Aluminium, anodized

Length 3 m

Length 6 m

XLCD 3

XLCD 6

For connection of two conveyor beams side to side. See page 58.

Articulated beam section (vertical) XL



Application examples

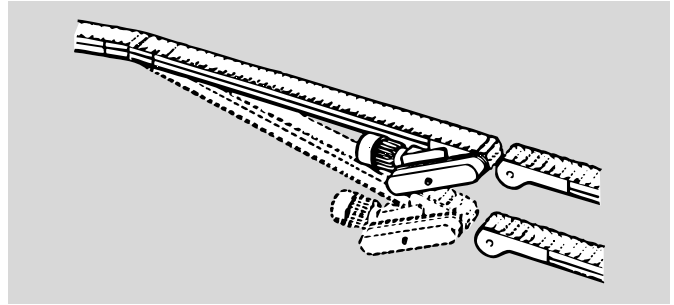

A vertically articulated beam section can be used for the transfer of goods from one conveyor to two or more conveyors.

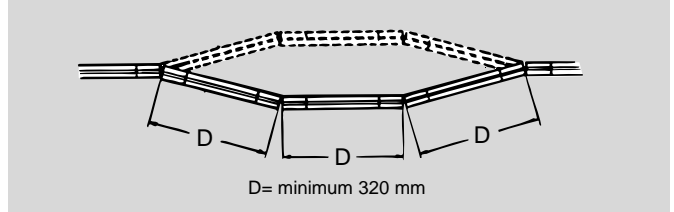

A vertically adjustable beam section can be the solution when products with different heights are to be handled by picking or placing equipment.

Example: PET bottles with differing heights leaving a moulding machine.

Introduction

In some applications it is desirable to be able to alter the vertical position of a conveyor beam. With an articulated beam section it is possible to adjust the conveyor beam up to $\pm 5^\circ$. The articulated beam section consists of two short pieces of conveyor beam connected by a hinge. Connecting strips are included.

Installation of slide rails

- Cut the slide rail as shown
- Note the cutting angle versus direction of transport
- Fix the ends with plastic screws as shown.

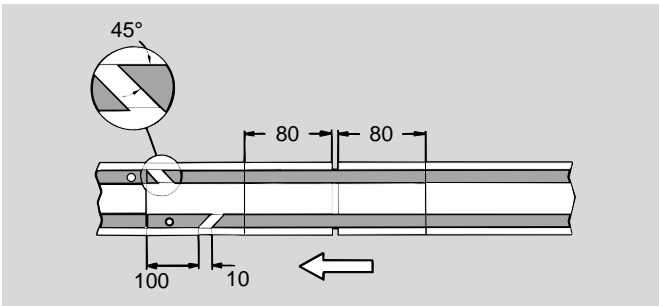

Articulated beam section XL

Articulated beam section

XL

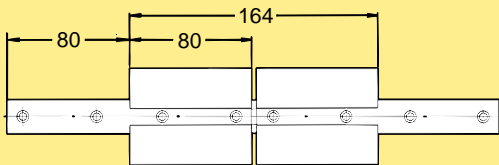

Articulated beam section vertical **XLCH 5 V**