

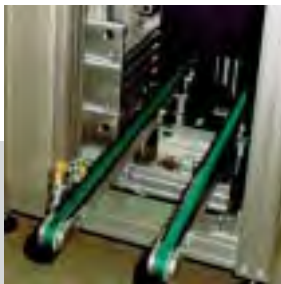



mk Lift- and Transfer Stations



Contents mk Lift- and Transfer Stations

| | | |
|---|---------------------------------|-----|
|  | Accumulating Conveyor with Lift | 296 |
|  | Lift and Transfer | 297 |
|  | Elevator | 298 |
|  | Vertical Storage | 299 |

Lift- and Transfer Stations

Accumulating Conveyor with Lift

Elevator with conveyors, material handling line for headlamps on pallets

Standard Components:

- Upper Conveyor: 2-Lane SRF-P 2012
- Linear Module: 2 x mk 2034/2004
- Elevator Conveyor: 2-Lane GUF-P 2000
- Return Conveyor: SRF-P 2012
- mk Structural Profile Frame

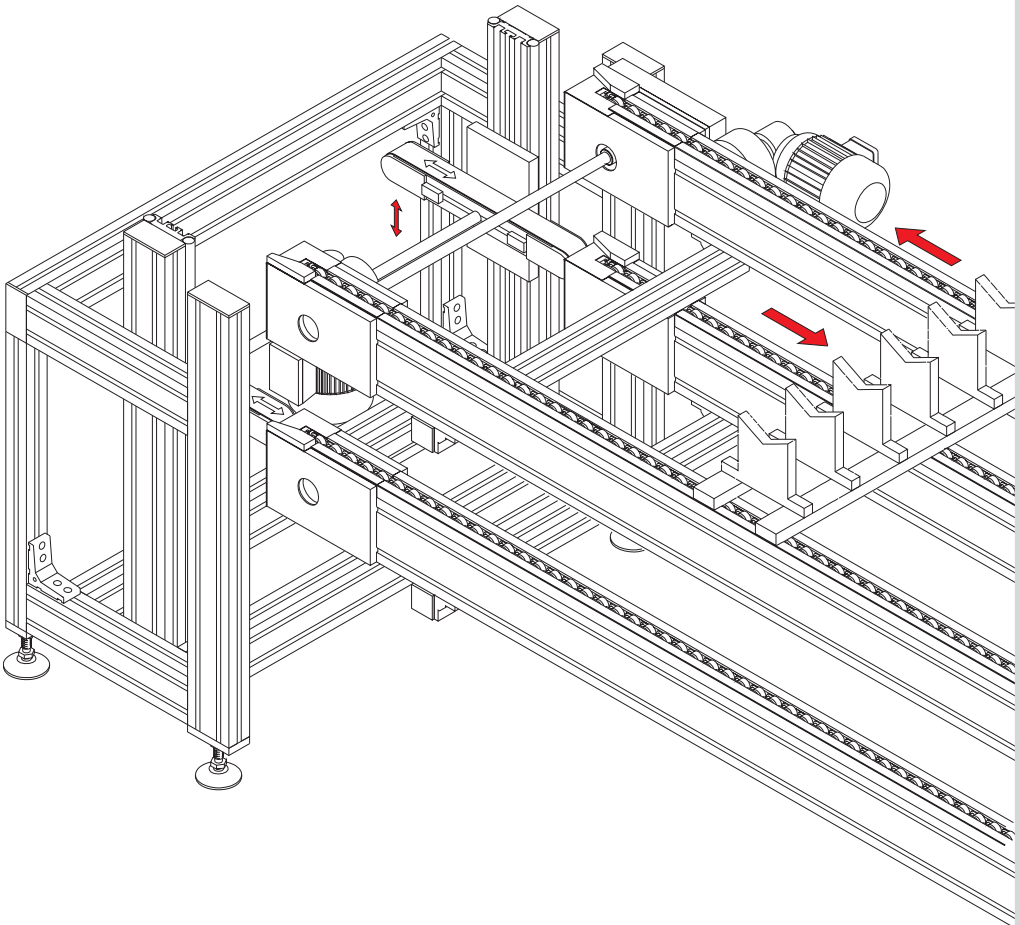

Lift and Transfer

Lift station with right angle transfer,
Pallet handling conveyor system

Standard Components:

- Conveyors: 2-Lane SRF-P 2012
- Linear Module: mk 2034/2005
- Transfer: 2-Lane GUF-P 2000
- mk Structural Profile Frame

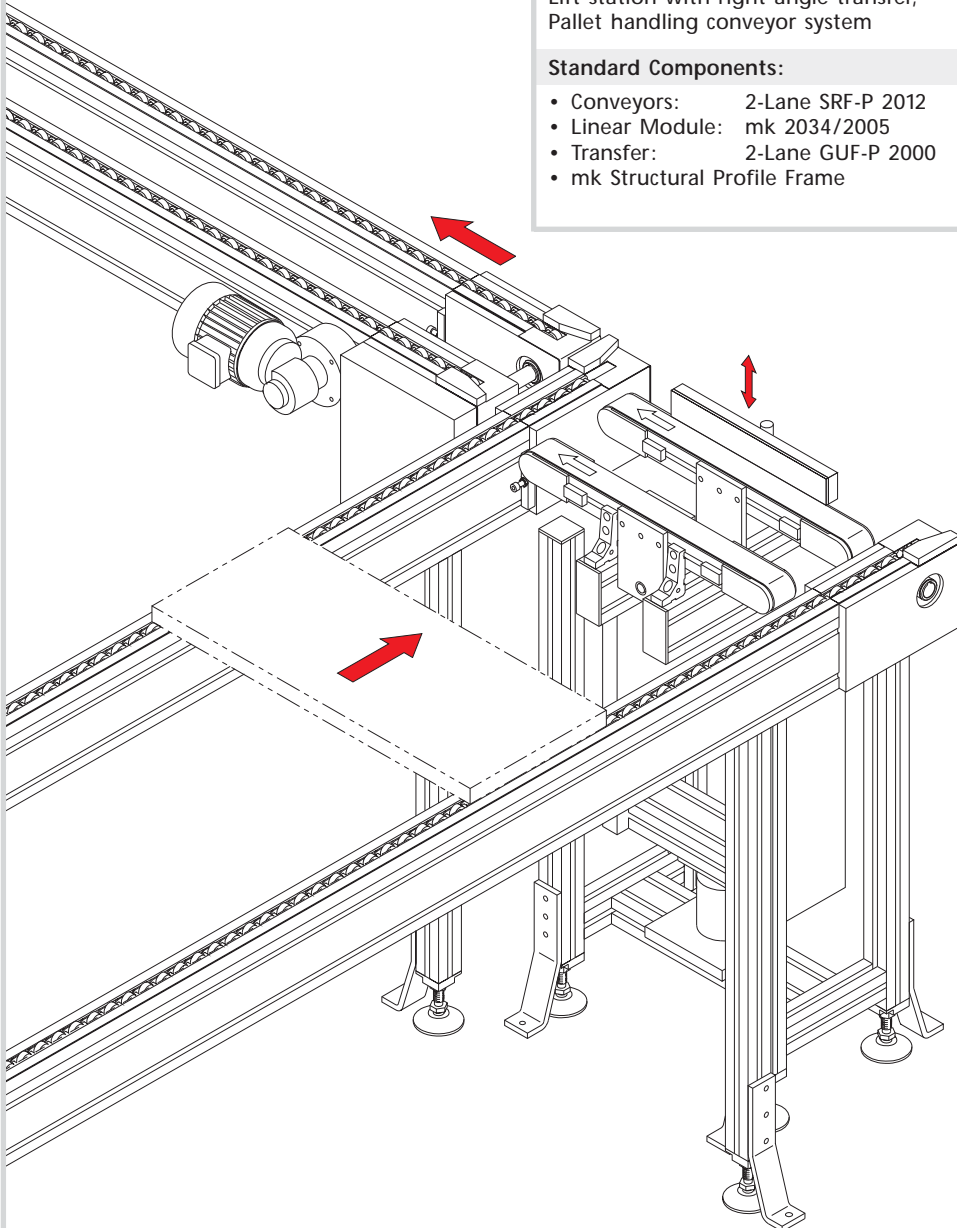

Lift- and Transfer Stations

Elevator

Elevator with right angle transfer,
pallet handling line

Standard Components:

- Conveyors: 2-Lane KTF-P 2010
- Conveyors: 2-Lane ZRF-P 2010
- Linear Module: 2 x mk 2034/2005
- Transfer: 2-Lane KTF-P 2010
- mk Structural Profile Frame

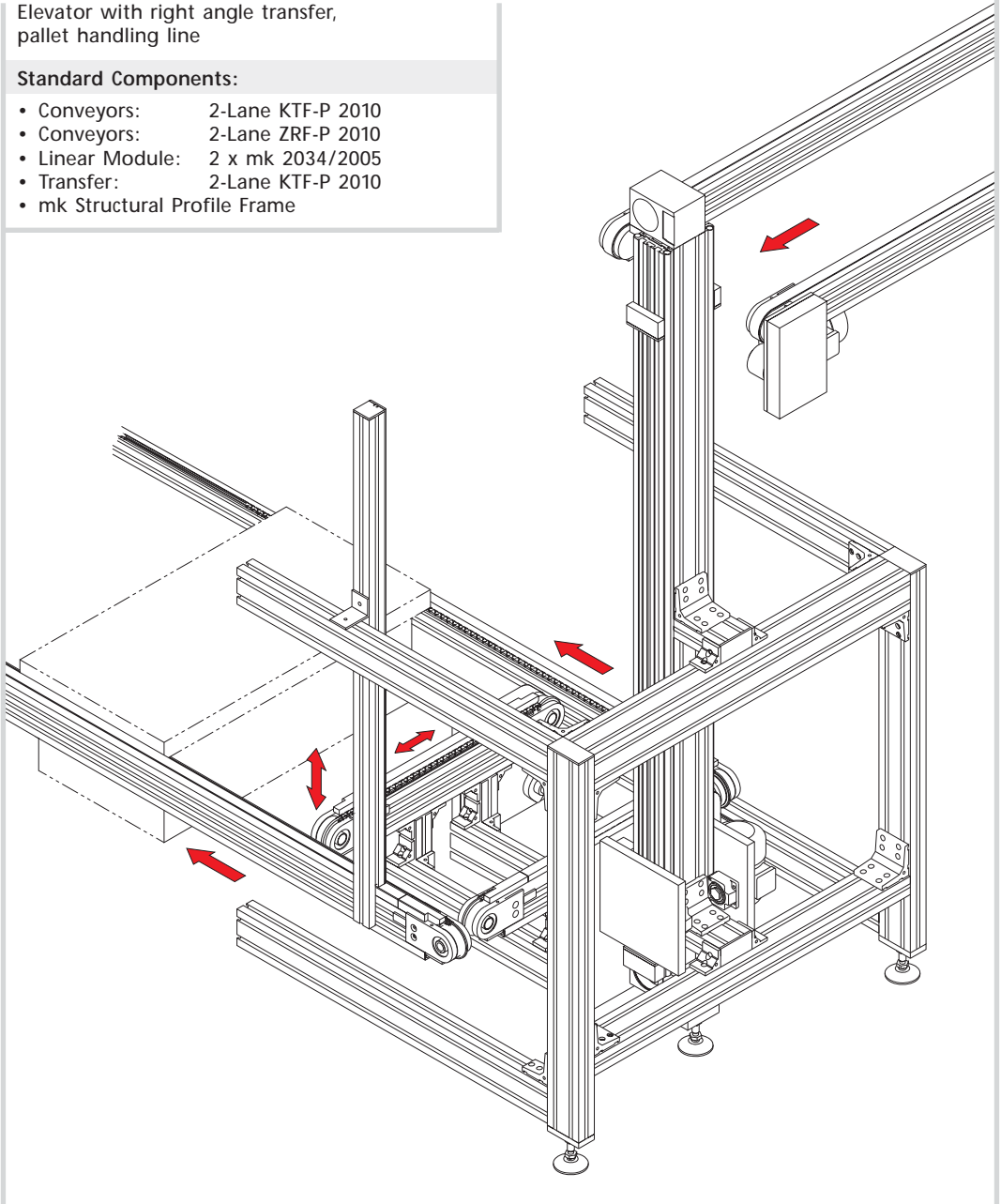

Vertical Storage

Pallet Handling

Standard Components:

- Lower Conveyor: 2-Lane KTF-P 2010
- Linear Module: 2 x mk 2034/2005
- Upper Conveyor: 2-Lane ZRF-P 2010
- mk Structural Profile Frame

