



Product Overview:

Shibuya Hoppmann's standard FTF-50 rigid disc centrifugal feeder is designed to feed a variety of products in a food-grade environment with its unique bowl design. Product is metered into the bowl and brought out to the bowl rim where a series of qualifiers gently orient the part for transfer to various downstream inline devices.

Part Number	FT501RLDFA	FT501RLAFA
Motor Style	DC	AC
Motor Voltage	90V	208-230/460V
Horsepower	3/4hp	3/4hp
Total Equipment Weight	1050 lbs.	476 kg

Standard Features:

- All stainless steel exterior construction
- FDA approved ABS vacuum formed disc
- Teflon Hardcoat Anodized aluminium bowl
- Square tooling frame
- Washdown motor(s)
- Upgraded drive components

Available Options:

- Polycarbonate covers
- Dual motor drive system

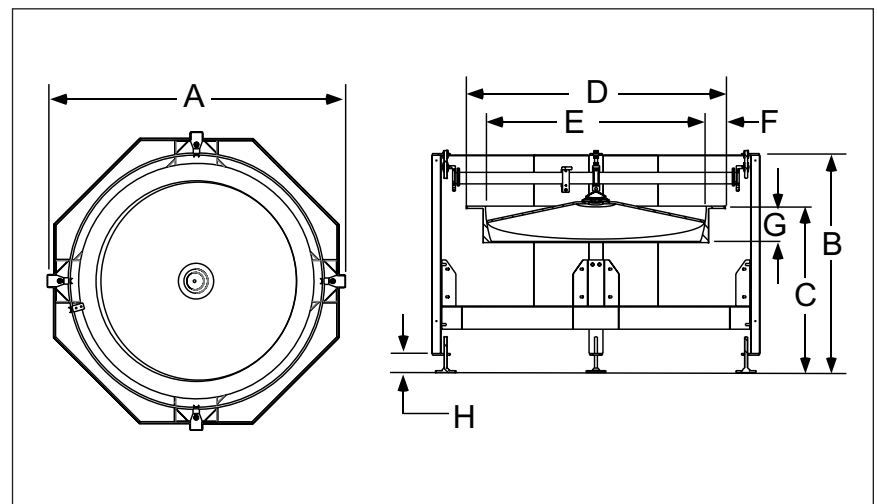

Required Accessories:

Clockwise: Backup Ring	BUCWFT50FU
Counter-Clockwise: Backup Ring	BUCCF50FU

Product Specifications	ANSI	Metric
A Outside Diameter	59"	1499mm
B Overall Height	47" ± 1.5"	1194 ± 38mm
C Discharge Height	36" ± 2"	914 ± 51mm
D Bowl Outside Diameter	43.46"	1104mm
E Bowl Inside Diameter	36.25"	921mm
F Rim Width	3.61"	92mm
G Bowl Depth	5.40"	137mm
H Level Foot Adjustment	5" ± 2.5"	127 ± 64mm

Headquarters
13129 Airpark Drive
Suite 120
Elkwood, VA 22718
540.829.2564 t
800.368.3582 t
540.829.1726 f

Sales
1445 Brookville Way
Suite F
Indianapolis, IN 46239
317.322.0754 t
800.368.3582 t
317.322.0794 f

Manufacturing
291 Dillard Road
Madison Heights, VA
24572
434.929.4746 t
800.543.0915 t
434.929.4959 f

Shibuya Hoppmann Corporation strives to improve its products and reserves the right to change or discontinue specifications & designs shown in this brochure without notice and without incurring obligation. Revised: 05/12.